

**SERIES FRONT SET  
ALUMINUM WINDOW WALL SYSTEM**

THIS SYSTEM MAY BE USED IN CONJUNCTION WITH F.B.C. APPROVED LARGE MISSILE IMPACT RESISTANT DOORS. LOWER DESIGN PRESSURE FROM STOREFRONT OR DOOR APPROVAL WILL APPLY TO ENTIRE SYSTEM.

THIS PRODUCT HAS BEEN DESIGNED AND TESTED TO COMPLY WITH THE REQUIREMENTS OF THE 2023 (8TH EDITION) FLORIDA BUILDING CODE INCLUDING HIGH VELOCITY HURRICANE ZONE (HVHZ).

1BY OR 2BY WOOD BUCKS & BUCK FASTENERS BY OTHERS, MUST BE DESIGNED AND INSTALLED ADEQUATELY TO TRANSFER APPLIED PRODUCT LOADS TO THE BUILDING STRUCTURE.

ANCHORS SHALL BE CORROSION RESISTANT, SPACED AS SHOWN ON DETAILS AND INSTALLED PER MANUF'S INSTRUCTIONS. SPECIFIED EMBEDMENT TO BASE MATERIAL SHALL BE BEYOND WALL DRESSING OR STUCCO.

A LOAD DURATION INCREASE IS USED IN DESIGN OF ANCHORS INTO WOOD ONLY.

ALL SHIMS TO BE HIGH IMPACT, NON-METALLIC AND NON-COMPRESSIBLE.

MATERIALS INCLUDING BUT NOT LIMITED TO STEEL/METAL SCREWS, THAT COME INTO CONTACT WITH OTHER DISSIMILAR MATERIALS SHALL MEET THE REQUIREMENTS OF THE 2023 FLORIDA BLDG. CODE & ADOPTED STANDARDS.

THIS PRODUCT APPROVAL IS GENERIC AND DOES NOT PROVIDE INFORMATION FOR A SITE SPECIFIC PROJECT, i.e. LIFE SAFETY OF THIS PRODUCT, ADEQUACY OF STRUCTURE RECEIVING THIS PRODUCT AND SEALING AROUND OPENING FOR WATER INFILTRATION RESISTANCE ETC. CONDITIONS NOT SHOWN IN THIS DRAWING ARE TO BE ANALYZED SEPARATELY, AND TO BE REVIEWED BY BUILDING OFFICIAL.

DESIGN LOADS SHOWN ARE BASED ON 'ALLOWABLE STRESS DESIGN (ASD)'.

MANUFACTURER'S LABEL SHALL BE LOCATED ON A READILY VISIBLE LOCATION IN ACCORDANCE WITH SECTION 1709.9.3 OF FLORIDA BUILDING CODE. LABELING TO COMPLY WITH SECTION 1709.9.2.

**TYPICAL ELEVATIONS**

**INSTRUCTIONS:** USE CHARTS AS FOLLOWS.

- STEP 1** DETERMINE DESIGN WIND PRESSURE REQUIREMENTS BASED ON WIND VELOCITY, BLDG. HEIGHT, WIND ZONE USING APPLICABLE ASCE 7 STANDARD.
- STEP 2** SEE CHARTS ON SHEETS 3 THRU 6.1 FOR DESIGN LOAD CAPACITY OF DESIRED GLASS SIZE.
- STEP 3** CHECK MULLION DESIGN LOAD CAPACITY FOR A GIVEN SPACING AND HEIGHT USING CHARTS ON SHEETS 7 THRU 11.1. THE CAPACITY SHOULD EXCEED THE DESIGN LOAD.
- STEP 4** USING CHARTS ON SHEETS 12 THRU 15 SELECT ANCHOR OPTION WITH DESIGN LOAD CAPACITY MORE THAN DESIGN LOAD SPECIFIED IN STEP 1 ABOVE.
- STEP 5** THE LOWEST VALUE RESULTING FROM STEPS 2, 3 AND 4 THAT EXCEED THE DESIGN WIND PRESSURES DETERMINED THRU STEP 1 SHALL APPLY TO ENTIRE SYSTEM.
- STEP 6** FOR UNANCHORED JAMBS, USING SHEET 21, DETERMINE THE MIN. & MAX. GAP DIMENSIONS.
- STEP 7** WHEN USING THIS SYSTEM WITH DOORS, SEE SHEETS 16 THRU 19.1 FOR DOOR MULLION AND DOOR MULLION ANCHOR CAPACITY. THE LOWER VALUE OF THE DESIGN PRESSURE RATING FOR THE SYSTEM AND THE DOOR SHALL APPLY.

**SINGLE 'O' PANEL:**

FRAME WIDTH = D.L.O. WIDTH + 4.50"  
FRAME HEIGHT = D.L.O. HEIGHT + 4.50"

PRODUCT COMPLIES WITH REQUIREMENTS OF ANSI Z97.1.

THIS SYSTEM IS RATED FOR LARGE & SMALL MISSILE IMPACT. SHUTTERS ARE NOT REQUIRED. WINDOW WALL FRAMES MAY BE WITH OR WITHOUT THERMAL BREAK.

Sealed: 8/19/2025

FL #19973

A- CONTRACTOR TO BE RESPONSIBLE FOR THE SELECTION, PURCHASE AND INSTALLATION OF THIS PRODUCT BASED ON THIS PRODUCT EVALUATION PROVIDED HE/SHE DOES NOT DEVIATE FROM THE CONDITIONS DETAILED ON THIS DOCUMENT.  
B- THIS PRODUCT EVALUATION DOCUMENT WILL BE CONSIDERED INVALID IF ALTERED BY ANY MEANS.  
C- SITE SPECIFIC PROJECTS SHALL BE PREPARED BY A FLORIDA REGISTERED ENGINEER OR ARCHITECT WHICH WILL BECOME THE ENGINEER OF RECORD (E.O.R.) FOR THE PROJECT AND WHO WILL BE RESPONSIBLE FOR THE PROPER USE OF THE P.E.D. ENGINEER OF RECORD, ACTING AS A DELEGATED ENGINEER TO THE P.E.D. ENGINEER SHALL SUBMIT TO THIS LATTER THE SITE SPECIFIC DRAWINGS FOR REVIEW.  
D- THIS P.E.D. SHALL BEAR THE DATE AND ORIGINAL SEAL AND SIGNATURE OF THE PROFESSIONAL ENGINEER OF RECORD THAT PREPARED IT.

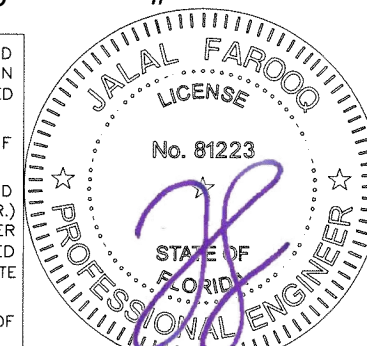

**af c**  
**AL-FAROOQ CORPORATION**  
ENGINEERS & PRODUCT DEVELOPMENT  
9360 SUNSET DRIVE, SUITE 220  
MIAMI, FLORIDA 33173 (C.A.N. 3538)  
TEL. (305) 264-8100 FAX. (305) 262-6978  
COMP-ANL\21-51FAGP

SERIES FRONT SET ALUM WINDOW WALL SYS. (L.M.I.)  
**Aldora Aluminum & Glass Products Inc.**  
4250 Coral Ridge Drive, Suite 101  
Coral Springs, FL 33065  
Tel. (954) 784-6900 Fax. (954) 784-6901

no	date	by	description
A	08.30.21		GLASS TYPE F1 ADDED
B	03.29.22		GLASS TYPES E & F ADDED
C	06.13.23		GLASS TYPE G ADDED
D	04.02.24		SHEET 2.1 ADDED
E	10.08.24		SHEET 5.1 REVISED

date: 06-10-21  
scale: 1/2"=1'-0"  
dr. by: TARIQ  
chk. by:

drawing no.  
**21-51F**

sheet 1 of 27

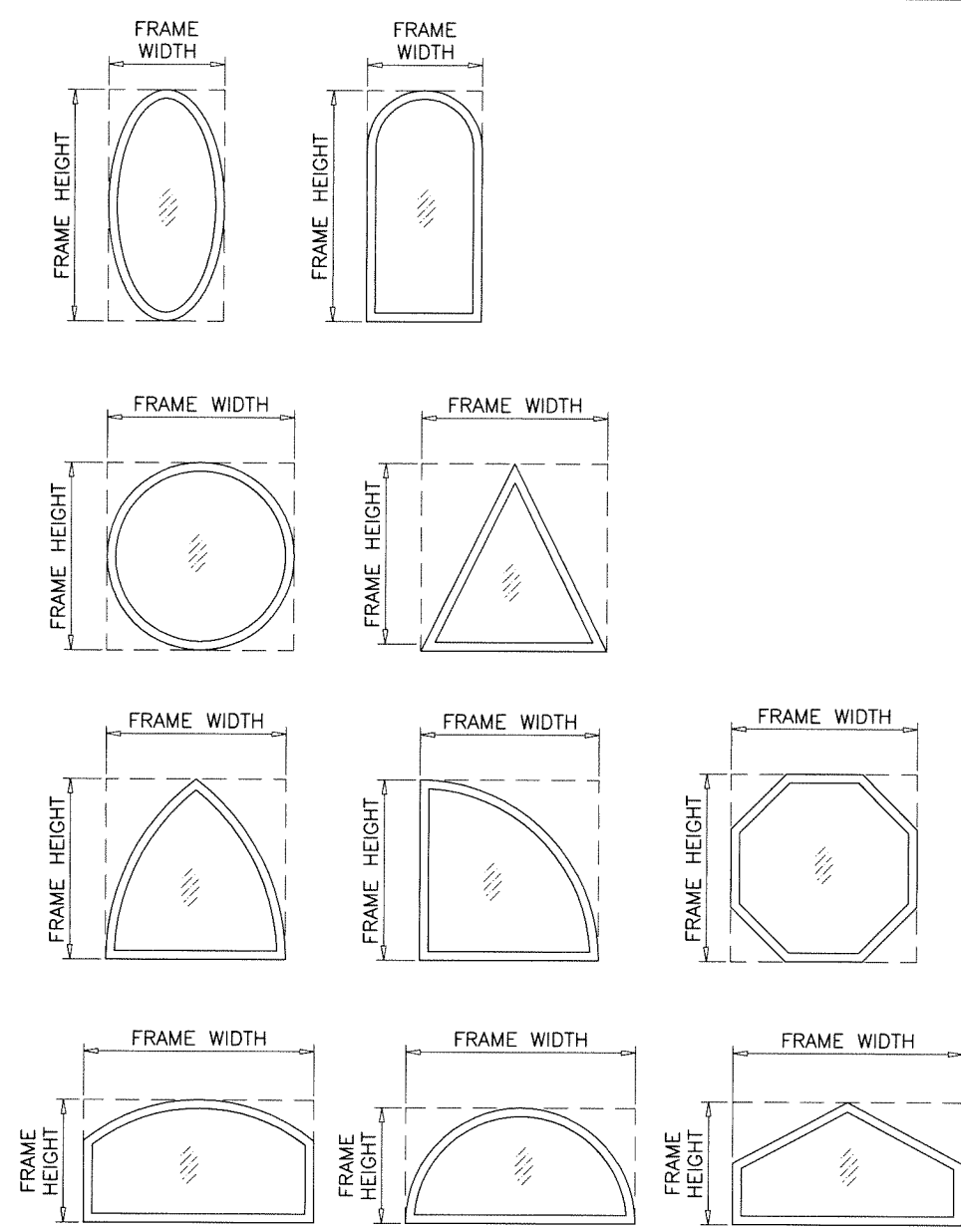
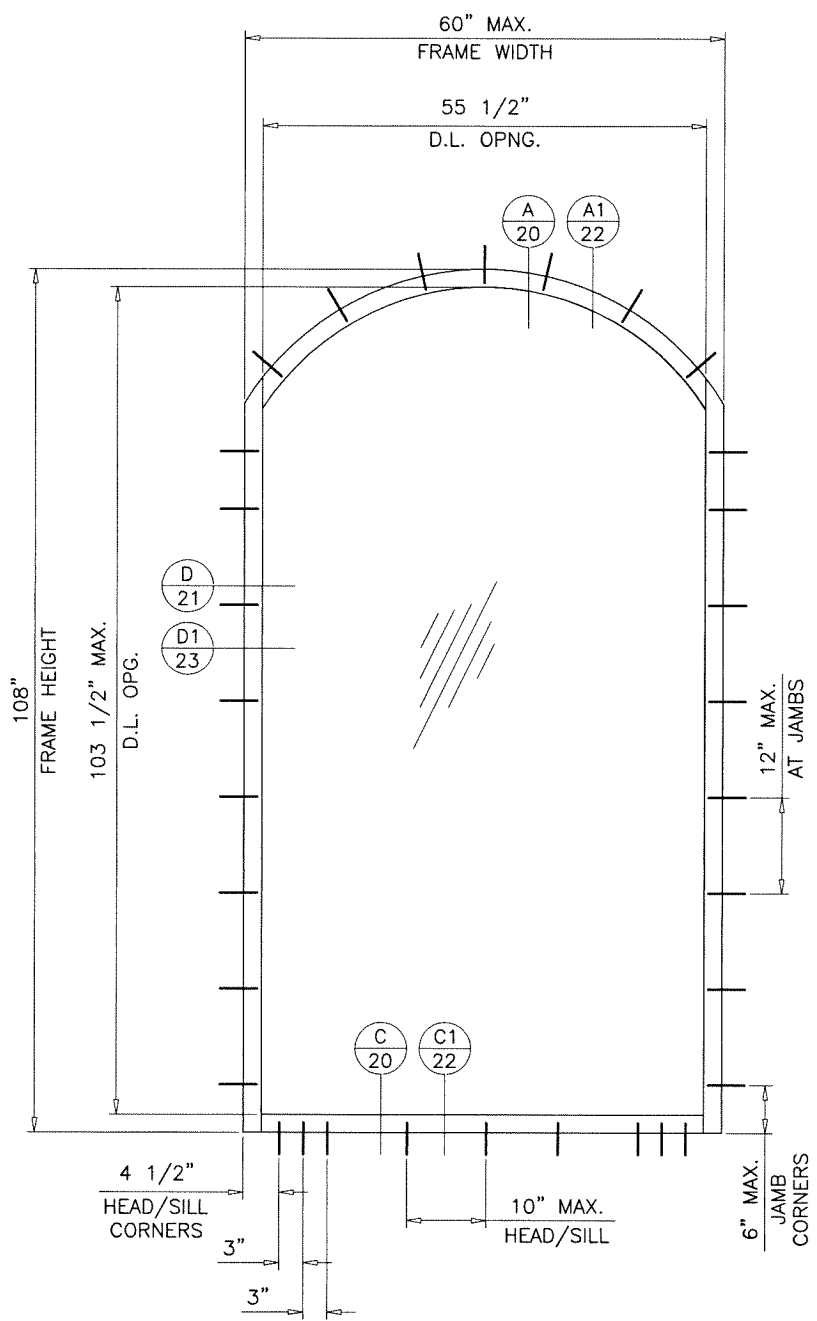
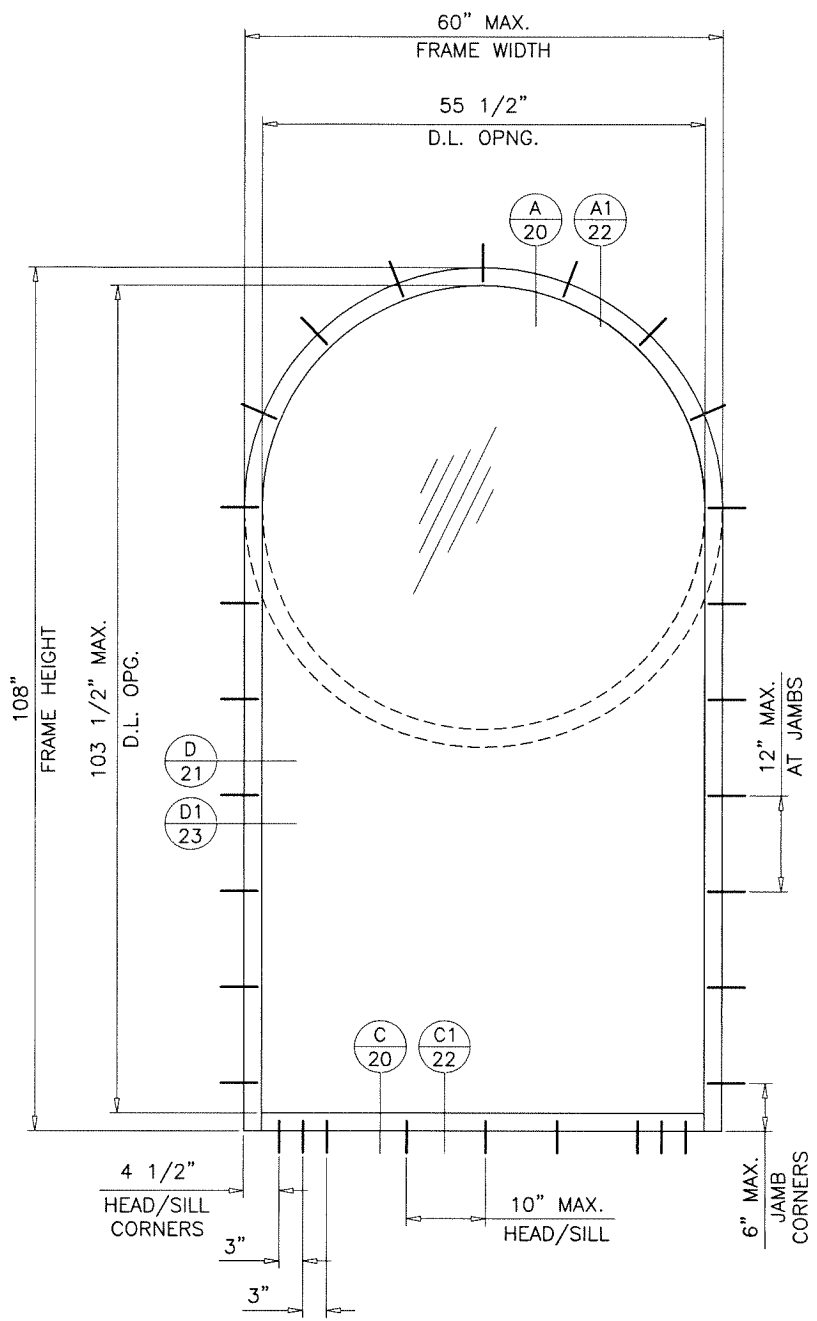

GLASS TYPE 'B' & 'Bi'  
 MAXIMUM DESIGN LOAD RATING = + 80.0 PSF  
 - 100.0 PSF  
 (FOR SHAPES AND SIZE SHOWN ON THIS SHEET ONLY)

ALLOWABLE LOADS FOR ALTERNATE SHAPES AS SHOWN ABOVE OR SIMILAR CAN BE VERIFIED BY INSCRIBING WINDOW SHAPE WITHIN SQUARE OR RECTANGLE AS SHOWN IN DOTTED LINES AND OBTAINING ALLOWABLE LOADS FROM THOSE SHAPES. INSTALLATION ANCHORS AT 4-1/2" FROM FRAME CORNERS AND 10" O.C. MAX.

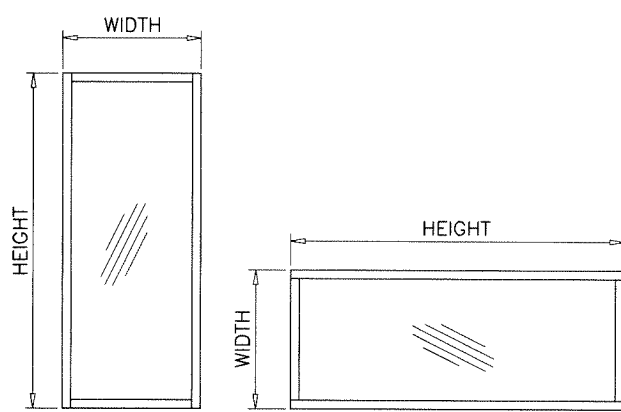

NOTE:  
 WIDTH AND HEIGHT DIMENSIONS CAN BE ORIENTED VERTICALLY OR HORIZONTALLY AS SHOWN ABOVE.

Sealed: 8/19/2025

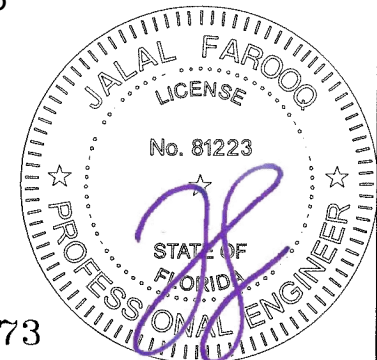

FL #19973

**af c**  
**AL-FAROOQ CORPORATION**  
 ENGINEERS & PRODUCT DEVELOPMENT  
 9360 SUNSET DRIVE, SUITE 220  
 MIAMI, FLORIDA 33173 (C.A.N. 3538)  
 TEL. (305) 264-8100 FAX. (305) 262-6978  
 COMP-ANL \ 21-51FAGP

SERIES FRONT SET ALUM WINDOWALL SYS. (L.M.I.)  
**Aldora Aluminum & Glass Products Inc.**  
 4250 Coral Ridge Drive, Suite 101  
 Coral Springs, FL. 33065  
 Tel. (954) 784-6900 Fax. (954) 784-6901

no	date	by	description

date: 06-10-21  
 scale: 1/2"=1'-0"  
 dr. by: TARIQ  
 chk. by:   
 drawing no.  
**21-51F**  
 sheet 2 of 27

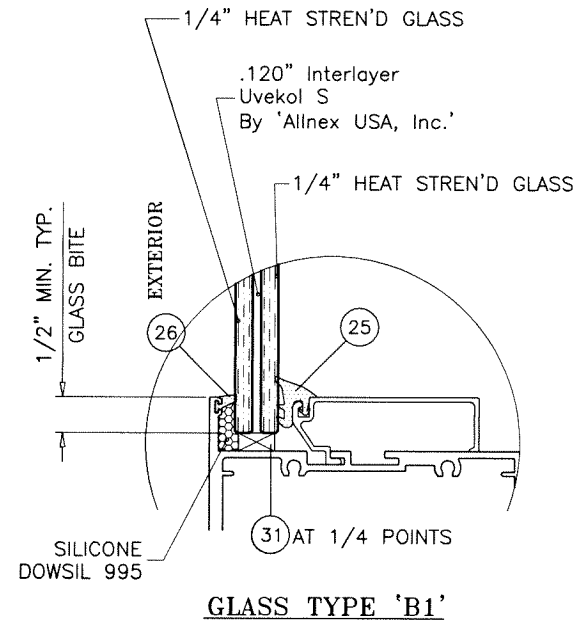
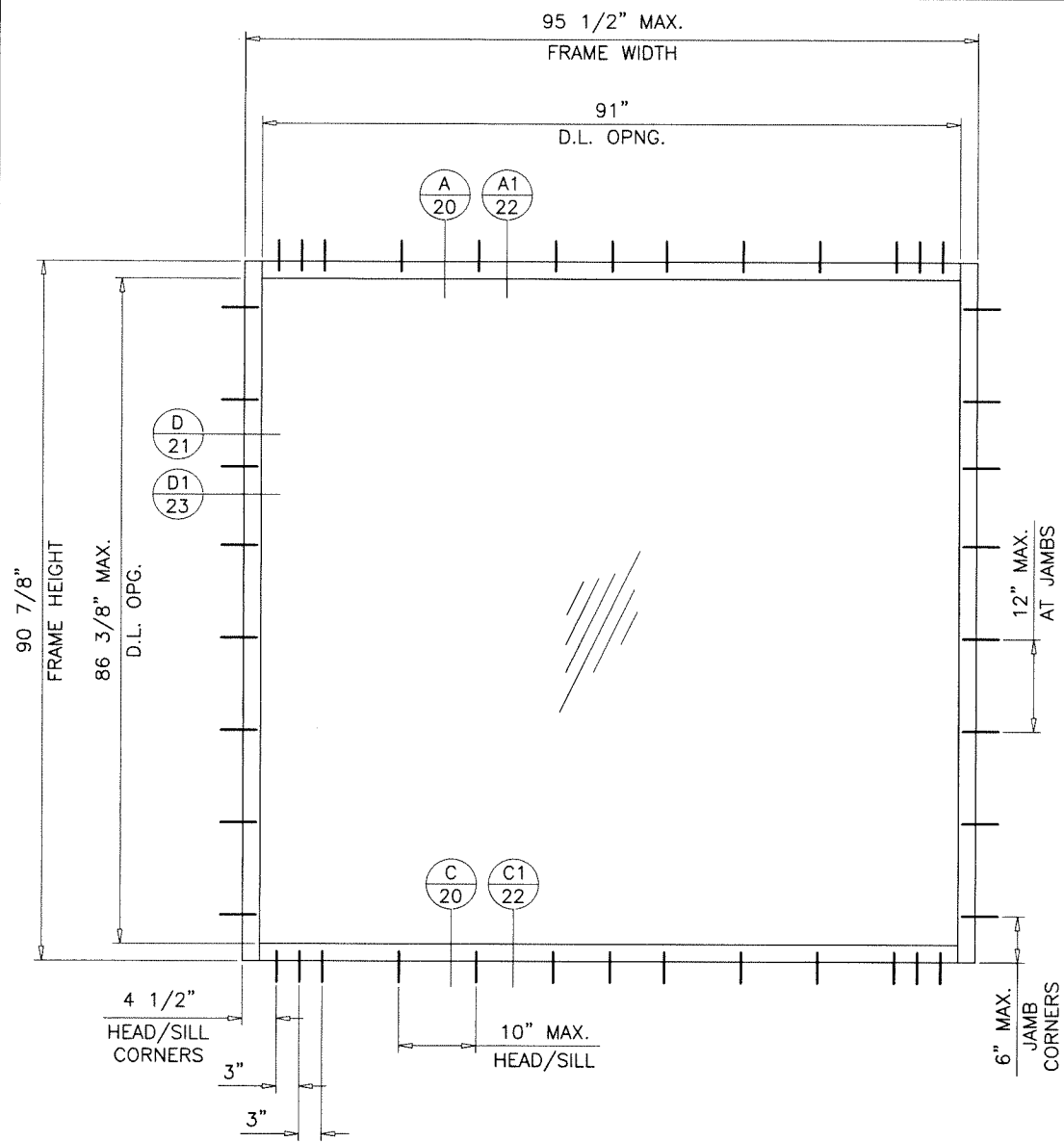

**GLASS TYPE 'B1'**  
 MAXIMUM DESIGN LOAD RATING = + 70.0 PSF  
 - 70.0 PSF  
 (FOR SIZE SHOWN ON THIS SHEET ONLY)

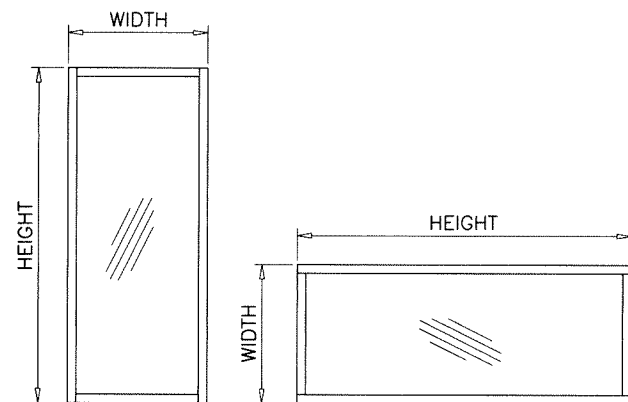

NOTE:  
 WIDTH AND HEIGHT DIMENSIONS CAN BE  
 ORIENTED VERTICALLY OR HORIZONTALLY  
 AS SHOWN ABOVE.

Sealed: 8/19/2025



FL #19973

**af c**  
**AL-FAROOQ CORPORATION**  
 ENGINEERS & PRODUCT DEVELOPMENT  
 9360 SUNSET DRIVE, SUITE 220 (C.A.N. 3538)  
 MIAMI, FLORIDA 33173  
 TEL. (305) 264-8100 FAX. (305) 262-6978  
 COMP-ANL\21-51FAGP

SERIES FRONT SET ALUM WINDOW WALL SYS. (L.M.I.)  
**Aldora Aluminum & Glass Products Inc.**  
 4250 Coral Ridge Drive, Suite 101  
 Coral Springs, FL. 33065  
 Tel. (954) 784-6900 Fax. (954) 784-6901

no	date	by	description

date: 06-10-21  
 scale: 1/2"=1'-0"  
 dr. by: TARIQ  
 chk. by:

drawing no.  
**21-51F**  
 sheet 2.1 of 27

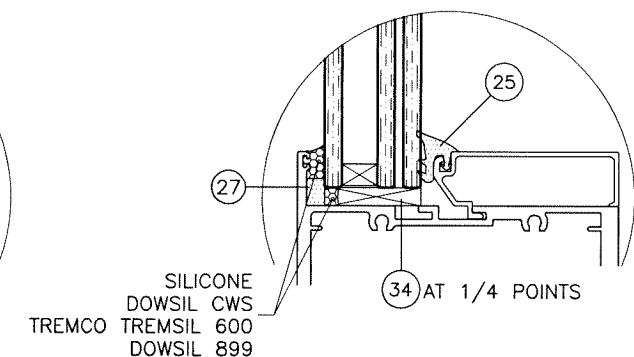
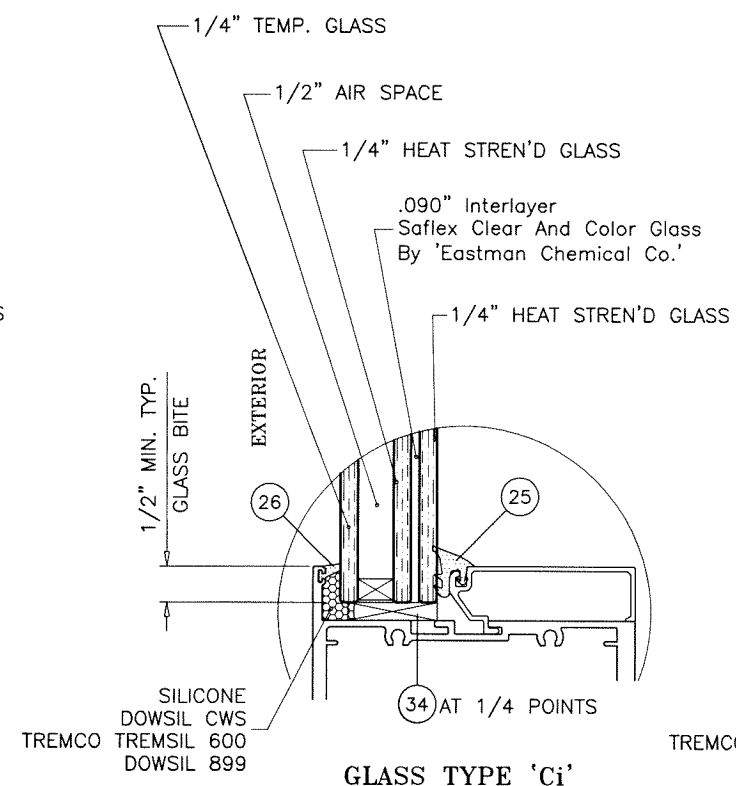
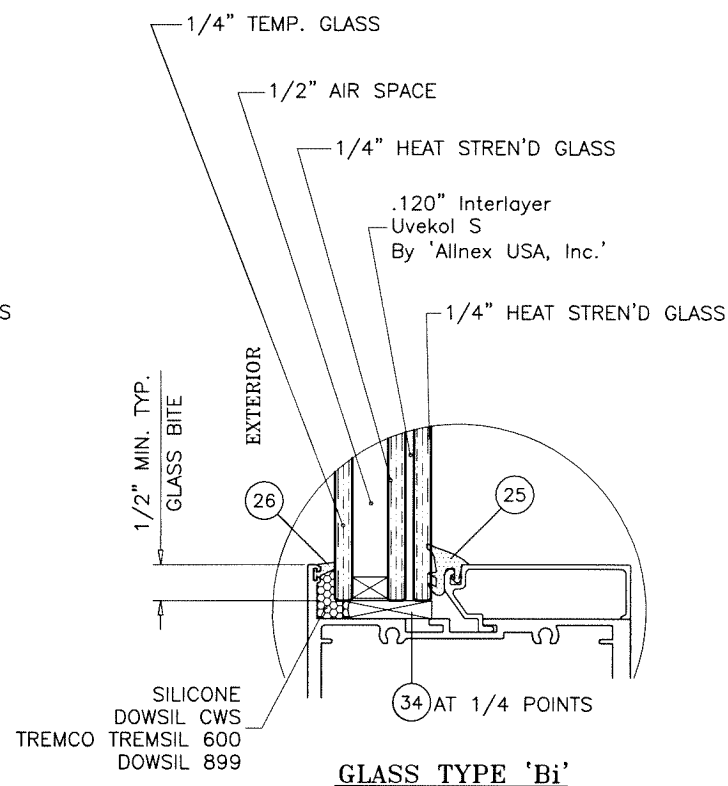
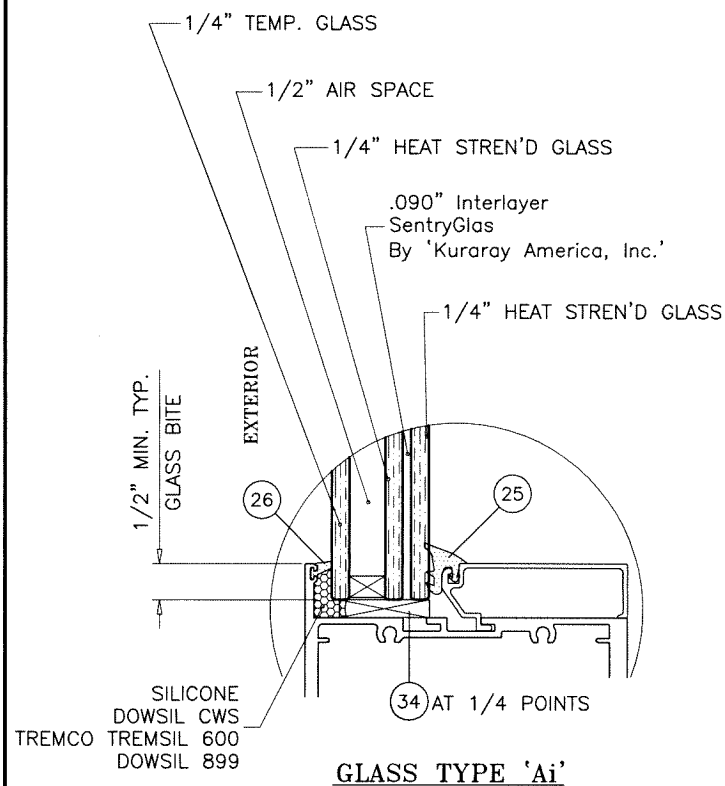
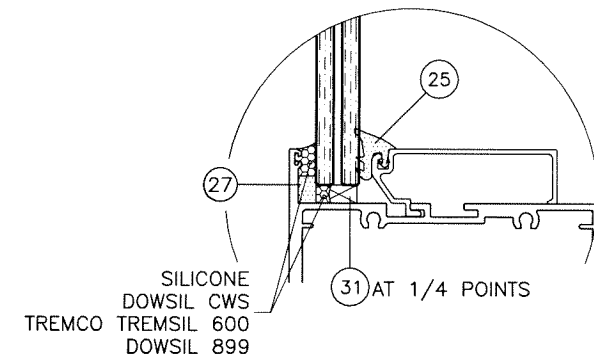
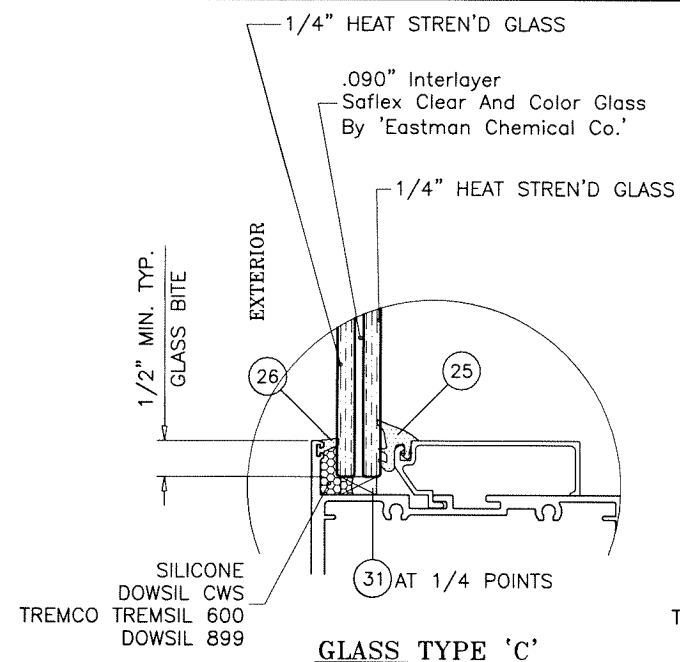
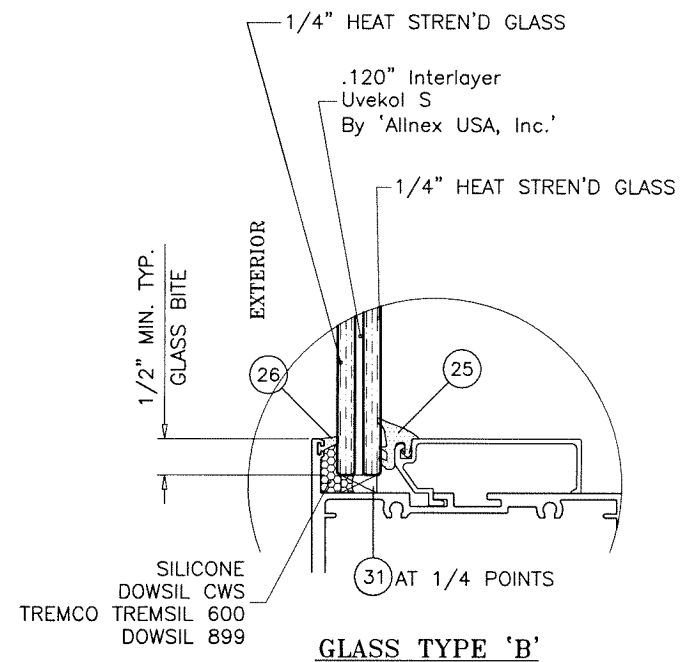
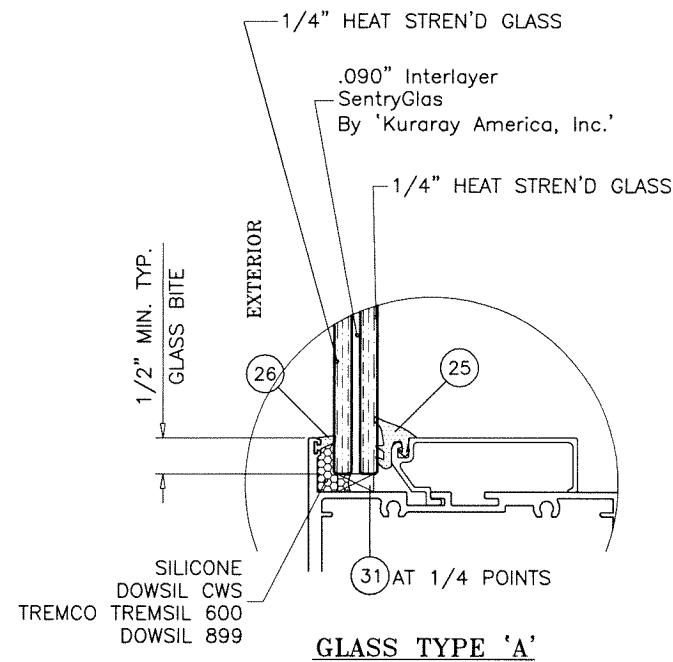

1/2" AIR SPACE CONSISTING OF:  
SPACER:  
'PROFIGLASS' ALUMINUM SPACER  
BY 'RAMAPO USA'  
PERIMETER SEALANT:  
SILICONE  
DOWSIL CWS  
DOWSIL 899  
GE 2000  
PECORA 895

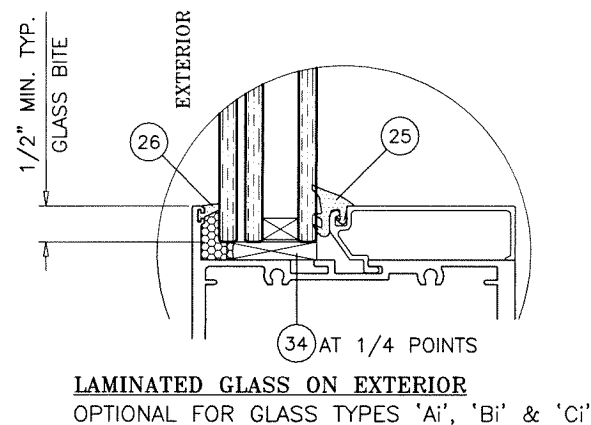

**GLAZING DETAILS LEVEL 'D' IMPACT**

**GLASS**  
(LEVEL 'D' IMPACT)

Sealed: 8/19/2025

FL #19973

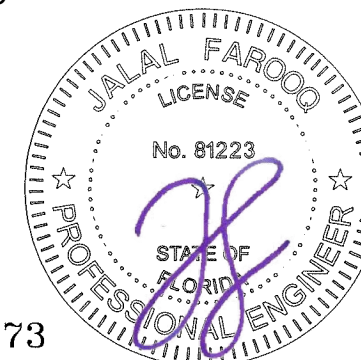

**af c**  
**AL-FAROOQ CORPORATION**  
ENGINEERS & PRODUCT DEVELOPMENT  
9360 SUNSET DRIVE, SUITE 220 (C.A.N. 3538)  
MIAMI, FLORIDA 33173  
TEL. (305) 264-8100 FAX. (305) 262-6978  
COMP-ANL\21-51FAGP

SERIES FRONT SET ALUM WINDOW WALL SYS. (L.M.I.)  
**Aldora Aluminum & Glass Products Inc.**  
4250 Coral Ridge Drive, Suite 101  
Coral Springs, FL. 33065  
Tel. (954) 784-6900 Fax. (954) 784-6901

no	date	description

date: 06-10-21  
scale: 3/8" = 1"  
dr. by: TARIQ  
chk. by:

drawing no.  
**21-51F**  
sheet 3 of 27

GLASS LOAD CAPACITY - PSF							
NOMINAL DIMS.		GLASS TYPES					
		'A' & 'Ai'		'B' & 'Bi'		'C' & 'Ci'	
D.L.O. WIDTH	D.L.O. HEIGHT	EXT.(+)	INT.(-)	EXT.(+)	INT.(-)	EXT.(+)	INT.(-)
33"	73-1/2"	120.0	135.0	120.0	135.0	65.0	75.0
36"		120.0	135.0	120.0	135.0	65.0	75.0
39"		120.0	135.0	120.0	135.0	65.0	75.0
42"		120.0	135.0	120.0	135.0	65.0	75.0
45"		120.0	135.0	120.0	135.0	65.0	75.0
48"		120.0	135.0	120.0	135.0	65.0	75.0
51"		120.0	135.0	120.0	135.0	65.0	75.0
54"		120.0	135.0	120.0	135.0	65.0	75.0
57"		120.0	135.0	120.0	135.0	65.0	75.0
60"		120.0	135.0	120.0	135.0	65.0	75.0
63"		90.0	90.0	100.0	100.0	65.0	75.0
66"	80.0	80.0	100.0	100.0	65.0	75.0	
69"	80.0	80.0	100.0	100.0	65.0	75.0	
33"	79-1/2"	120.0	135.0	120.0	135.0	65.0	75.0
36"		120.0	135.0	120.0	135.0	65.0	75.0
39"		120.0	135.0	120.0	135.0	65.0	75.0
42"		120.0	135.0	120.0	135.0	65.0	75.0
45"		120.0	135.0	120.0	135.0	65.0	75.0
48"		120.0	135.0	120.0	135.0	65.0	75.0
51"		120.0	135.0	120.0	135.0	65.0	75.0
54"		120.0	135.0	120.0	135.0	65.0	75.0
57"		90.0	90.0	100.0	100.0	65.0	75.0
60"		80.0	80.0	100.0	100.0	65.0	75.0
63"		80.0	80.0	100.0	100.0	65.0	75.0
66"	80.0	80.0	100.0	100.0	-	-	
69"	80.0	80.0	100.0	100.0	-	-	
33"	85-1/2"	120.0	135.0	120.0	135.0	65.0	75.0
36"		120.0	135.0	120.0	135.0	65.0	75.0
39"		120.0	135.0	120.0	135.0	65.0	75.0
42"		120.0	135.0	120.0	135.0	65.0	75.0
45"		120.0	135.0	120.0	135.0	65.0	75.0
48"		120.0	135.0	120.0	135.0	65.0	75.0
51"		120.0	135.0	120.0	135.0	65.0	75.0
54"		90.0	90.0	100.0	100.0	65.0	75.0
57"		80.0	80.0	100.0	100.0	65.0	75.0
60"		80.0	80.0	100.0	100.0	65.0	75.0
63"		80.0	80.0	100.0	100.0	-	-
66"	80.0	80.0	100.0	100.0	-	-	
69"	80.0	80.0	80.0	80.0	-	-	
33"	91-1/2"	120.0	135.0	120.0	135.0	65.0	75.0
36"		120.0	135.0	120.0	135.0	65.0	75.0
39"		120.0	135.0	120.0	135.0	65.0	75.0
42"		120.0	135.0	120.0	135.0	65.0	75.0
45"		120.0	135.0	120.0	135.0	65.0	75.0
48"		120.0	135.0	120.0	135.0	65.0	75.0
51"		80.0	80.0	100.0	100.0	65.0	75.0
54"		80.0	80.0	100.0	100.0	65.0	75.0
57"		80.0	80.0	100.0	100.0	-	-
60"		80.0	80.0	100.0	100.0	-	-
63"		80.0	80.0	80.0	80.0	-	-
66"	80.0	80.0	80.0	80.0	-	-	
69"	80.0	80.0	80.0	80.0	-	-	

GLASS LOAD CAPACITY - PSF							
NOMINAL DIMS.		GLASS TYPES					
		'A' & 'Ai'		'B' & 'Bi'		'C' & 'Ci'	
D.L.O. WIDTH	D.L.O. HEIGHT	EXT.(+)	INT.(-)	EXT.(+)	INT.(-)	EXT.(+)	INT.(-)
33"	97-1/2"	120.0	135.0	120.0	135.0	65.0	75.0
36"		120.0	135.0	120.0	135.0	65.0	75.0
39"		120.0	135.0	120.0	135.0	65.0	75.0
42"		120.0	135.0	120.0	135.0	65.0	75.0
45"		120.0	135.0	120.0	135.0	65.0	75.0
48"		80.0	80.0	100.0	100.0	65.0	75.0
51"		80.0	80.0	100.0	100.0	65.0	75.0
54"		80.0	80.0	100.0	100.0	-	-
57"		80.0	80.0	100.0	100.0	-	-
60"		80.0	80.0	80.0	80.0	-	-
63"		80.0	80.0	80.0	80.0	-	-
66"	80.0	80.0	80.0	80.0	-	-	
69"	60.0	60.0	80.0	80.0	-	-	
33"	103-1/2"	120.0	135.0	120.0	135.0	65.0	75.0
36"		120.0	135.0	120.0	135.0	65.0	75.0
39"		120.0	135.0	120.0	135.0	65.0	75.0
42"		120.0	135.0	120.0	135.0	65.0	75.0
45"		90.0	90.0	100.0	100.0	65.0	75.0
48"		80.0	80.0	100.0	100.0	65.0	75.0
51"		80.0	80.0	100.0	100.0	-	-
54"		80.0	80.0	100.0	100.0	-	-
57"		80.0	80.0	80.0	80.0	-	-
60"		80.0	80.0	80.0	80.0	-	-
63"		80.0	80.0	80.0	80.0	-	-
66"	60.0	60.0	80.0	80.0	-	-	
69"	60.0	60.0	80.0	80.0	-	-	
33"	109-1/2"	120.0	135.0	120.0	135.0	65.0	75.0
36"		120.0	135.0	120.0	135.0	65.0	75.0
39"		120.0	135.0	120.0	135.0	65.0	75.0
42"		90.0	90.0	100.0	100.0	65.0	75.0
45"		80.0	80.0	100.0	100.0	65.0	75.0
48"		80.0	80.0	100.0	100.0	-	-
51"		80.0	80.0	100.0	100.0	-	-
54"		80.0	80.0	80.0	80.0	-	-
57"		80.0	80.0	80.0	80.0	-	-
60"		80.0	80.0	80.0	80.0	-	-
63"		60.0	60.0	80.0	80.0	-	-
66"	60.0	60.0	80.0	80.0	-	-	
69"	60.0	60.0	80.0	80.0	-	-	
33"	115-1/2"	120.0	135.0	120.0	135.0	65.0	75.0
36"		120.0	135.0	120.0	135.0	65.0	75.0
39"		120.0	135.0	120.0	135.0	65.0	75.0
42"		80.0	80.0	100.0	100.0	65.0	75.0
45"		80.0	80.0	100.0	100.0	65.0	75.0
48"		80.0	80.0	100.0	100.0	-	-
51"		80.0	80.0	80.0	80.0	-	-
54"		80.0	80.0	80.0	80.0	-	-
57"		80.0	80.0	80.0	80.0	-	-
60"		60.0	60.0	80.0	80.0	-	-
63"		60.0	60.0	80.0	80.0	-	-
66"	60.0	60.0	80.0	80.0	-	-	
69"	60.0	60.0	80.0	80.0	-	-	

GLASS LOAD CAPACITY - PSF								
NOMINAL DIMS.		GLASS TYPES						
		'A' & 'Ai'		'B' & 'Bi'		'C' & 'Ci'		
D.L.O. WIDTH	D.L.O. HEIGHT	EXT.(+)	INT.(-)	EXT.(+)	INT.(-)	EXT.(+)	INT.(-)	
33"	121-1/2"	120.0	135.0	120.0	135.0	65.0	75.0	
36"		120.0	135.0	120.0	135.0	65.0	75.0	
39"		80.0	80.0	100.0	100.0	65.0	75.0	
42"		80.0	80.0	100.0	100.0	65.0	75.0	
45"		80.0	80.0	100.0	100.0	-	-	
48"		80.0	80.0	80.0	80.0	-	-	
51"		80.0	80.0	80.0	80.0	-	-	
54"		80.0	80.0	80.0	80.0	-	-	
57"		60.0	60.0	80.0	80.0	-	-	
60"		60.0	60.0	80.0	80.0	-	-	
63"		60.0	60.0	80.0	80.0	-	-	
33"	127-1/2"	120.0	135.0	120.0	135.0	65.0	75.0	
36"		90.0	90.0	100.0	100.0	65.0	75.0	
39"		80.0	80.0	100.0	100.0	65.0	75.0	
42"		80.0	80.0	100.0	100.0	-	-	
45"		80.0	80.0	100.0	100.0	-	-	
48"		80.0	80.0	80.0	80.0	-	-	
51"		80.0	80.0	80.0	80.0	-	-	
54"		60.0	60.0	80.0	80.0	-	-	
57"		60.0	60.0	80.0	80.0	-	-	
60"		60.0	60.0	80.0	80.0	-	-	
63"		60.0	60.0	80.0	80.0	-	-	
33"	133-1/2"	120.0	135.0	120.0	135.0	65.0	75.0	
36"		80.0	80.0	100.0	100.0	65.0	75.0	
39"		80.0	80.0	100.0	100.0	-	-	
42"		80.0	80.0	100.0	100.0	-	-	
45"		80.0	80.0	80.0	80.0	-	-	
48"		80.0	80.0	80.0	80.0	-	-	
51"		60.0	60.0	80.0	80.0	-	-	
54"		60.0	60.0	80.0	80.0	-	-	
57"		60.0	60.0	80.0	80.0	-	-	
33"		139-1/2"	90.0	90.0	100.0	100.0	65.0	75.0
36"			80.0	80.0	100.0	100.0	65.0	75.0
39"	80.0		80.0	100.0	100.0	-	-	
42"	80.0		80.0	80.0	80.0	-	-	
45"	80.0		80.0	80.0	80.0	-	-	
48"	60.0		60.0	80.0	80.0	-	-	
51"	60.0		60.0	80.0	80.0	-	-	
54"	60.0		60.0	80.0	80.0	-	-	
57"	60.0		60.0	80.0	80.0	-	-	

INTERPOLATION BETWEEN WIDTHS OR HEIGHTS ALLOWED.

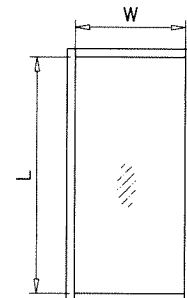
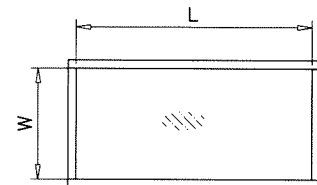
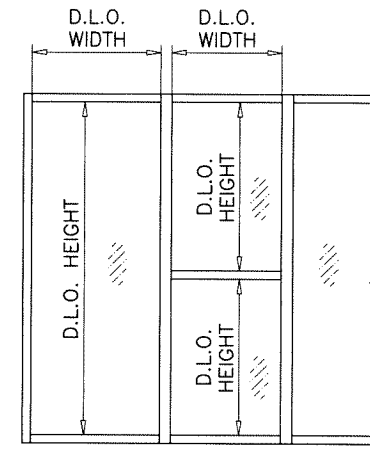

NOTE: WIDTH AND LENGTH DIMENSIONS CAN BE ORIENTED VERTICALLY OR HORIZONTALLY AS SHOWN ABOVE.

Sealed: 8/19/2025

NOTE: GLASS CAPACITIES ON THIS SHEET ARE BASED ON ASTM E1300-09 (3 SEC. GUSTS).

**GLASS**  
(LEVEL 'D' IMPACT)

JALAL FAROOQ  
LICENSE  
No. 81223  
STATE OF FLORIDA  
PROFESSIONAL ENGINEER

date: 06-10-21  
scale: -  
dr. by: TARIQ  
chk. by:

drawing no.  
**21-51F**  
sheet 4 of 27

FL #19973

**AL-FAROOQ CORPORATION**  
ENGINEERS & PRODUCT DEVELOPMENT  
9360 SUNSET DRIVE, SUITE 220  
MIAMI, FLORIDA 33173 (C.A.N. 3538)  
TEL. (305) 264-8100 FAX. (305) 262-6978  
COMP-ANL 21-51FAGP

SERIES FRONT SET ALUM WINDOWALL SYS. (L.M.I.)  
**Aldora Aluminum & Glass Products Inc.**  
4250 Coral Ridge Drive, Suite 101  
Coral Springs, FL. 33065  
Tel. (954) 784-6900 Fax. (954) 784-6901

no	date	description

GLASS LOAD CAPACITY - PSF			
NOMINAL DIMS.		GLASS TYPE 'Di'	
D.L.O. WIDTH	D.L.O. HEIGHT	EXT.(+)	INT.(-)
33"	73-1/2"	65.0	65.0
36"		65.0	65.0
39"		65.0	65.0
42"		65.0	65.0
45"		65.0	65.0
48"		60.9	60.9
51"		57.4	57.4
54"		54.2	54.2
57"		51.3	51.3
60"		48.8	48.8
63"	46.4	46.4	
66"	44.3	44.3	
69"	42.4	42.4	
33"	79-1/2"	65.0	65.0
36"		65.0	65.0
39"		65.0	65.0
42"		65.0	65.0
45"		65.0	65.0
48"		60.9	60.9
51"		57.4	57.4
54"		54.2	54.2
57"		51.3	51.3
60"		48.8	48.8
63"	46.4	46.4	
33"	85-1/2"	65.0	65.0
36"		65.0	65.0
39"		65.0	65.0
42"		65.0	65.0
45"		65.0	65.0
48"		60.9	60.9
51"		57.4	57.4
54"		54.2	54.2
57"		51.3	51.3
60"		48.8	48.8
33"	91-1/2"	65.0	65.0
36"		65.0	65.0
39"		65.0	65.0
42"		65.0	65.0
45"		65.0	65.0
48"		60.9	60.9
51"	57.4	57.4	
54"	54.2	54.2	
33"	97-1/2"	65.0	65.0
36"		65.0	65.0
39"		65.0	65.0
42"		65.0	65.0
45"		65.0	65.0
48"		60.9	60.9
51"	57.4	57.4	

GLASS LOAD CAPACITY - PSF				
NOMINAL DIMS.		GLASS TYPE 'Di'		
D.L.O. WIDTH	D.L.O. HEIGHT	EXT.(+)	INT.(-)	
33"	103-1/2"	65.0	65.0	
36"		65.0	65.0	
39"		65.0	65.0	
42"		65.0	65.0	
45"		65.0	65.0	
48"		60.9	60.9	
33"	109-1/2"	65.0	65.0	
36"		65.0	65.0	
39"		65.0	65.0	
42"		65.0	65.0	
45"		65.0	65.0	
33"		115-1/2"	65.0	65.0
36"	65.0		65.0	
39"	65.0		65.0	
42"	65.0		65.0	
45"	65.0		65.0	
33"	121-1/2"		65.0	65.0
36"		65.0	65.0	
39"		65.0	65.0	
42"		65.0	65.0	
33"		127-1/2"	65.0	65.0
36"			65.0	65.0
39"	65.0		65.0	
33"	133-1/2"		65.0	65.0
36"			65.0	65.0
33"			139-1/2"	65.0
36"		65.0		65.0

INTERPOLATION BETWEEN WIDTHS OR HEIGHTS ALLOWED.

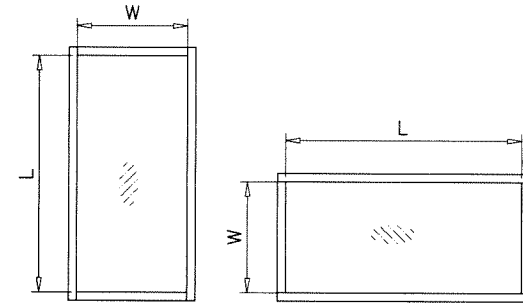
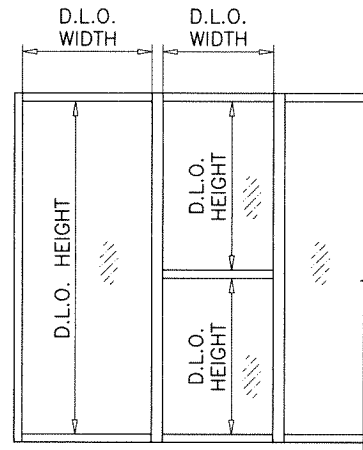

NOTE: WIDTH AND LENGTH DIMENSIONS CAN BE ORIENTED VERTICALLY OR HORIZONTALLY AS SHOWN ABOVE.

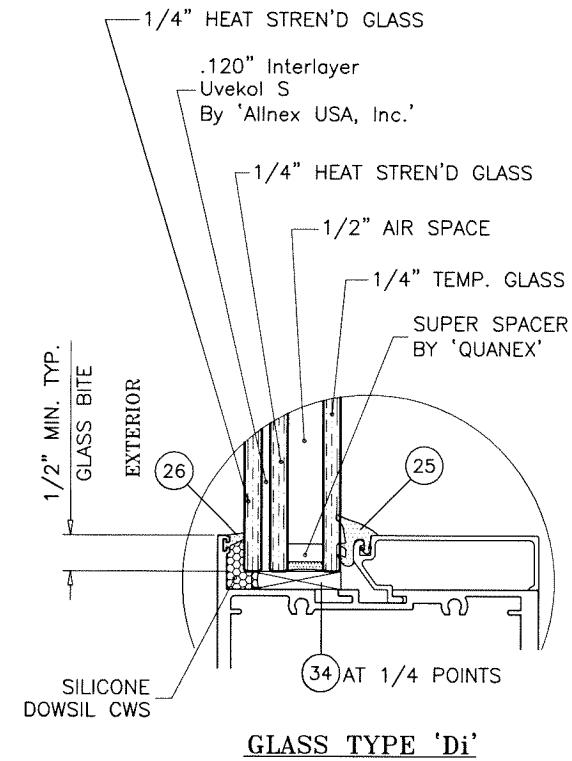

GLAZING DETAIL LEVEL 'D' IMPACT

Sealed: 8/19/2025

GLASS  
(LEVEL 'D' IMPACT)

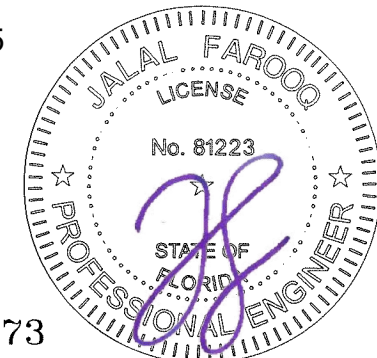

NOTE: GLASS CAPACITIES ON THIS SHEET ARE BASED ON ASTM E1300-09 (3 SEC. GUSTS).

FL #19973

**af c**  
**AL-FAROOQ CORPORATION**  
 ENGINEERS & PRODUCT DEVELOPMENT  
 9360 SUNSET DRIVE, SUITE 220 (C.A.N. 3538)  
 MIAMI, FLORIDA 33173  
 TEL. (305) 264-8100 FAX. (305) 262-6978  
 COMP-ANL\21-51FAGP

SERIES FRONT SET ALUM WINDOW WALL SYS. (L.M.I.)  
**Aldora Aluminum & Glass Products Inc.**  
 4250 Coral Ridge Drive, Suite 101  
 Coral Springs, FL. 33065  
 Tel. (954) 784-6900 Fax. (954) 784-6901

no	date	by	description

date: 06-10-21  
 scale: 3/8" = 1"  
 dr. by: TARIQ  
 chk. by:

drawing no.  
**21-51F**  
 sheet 5 of 27

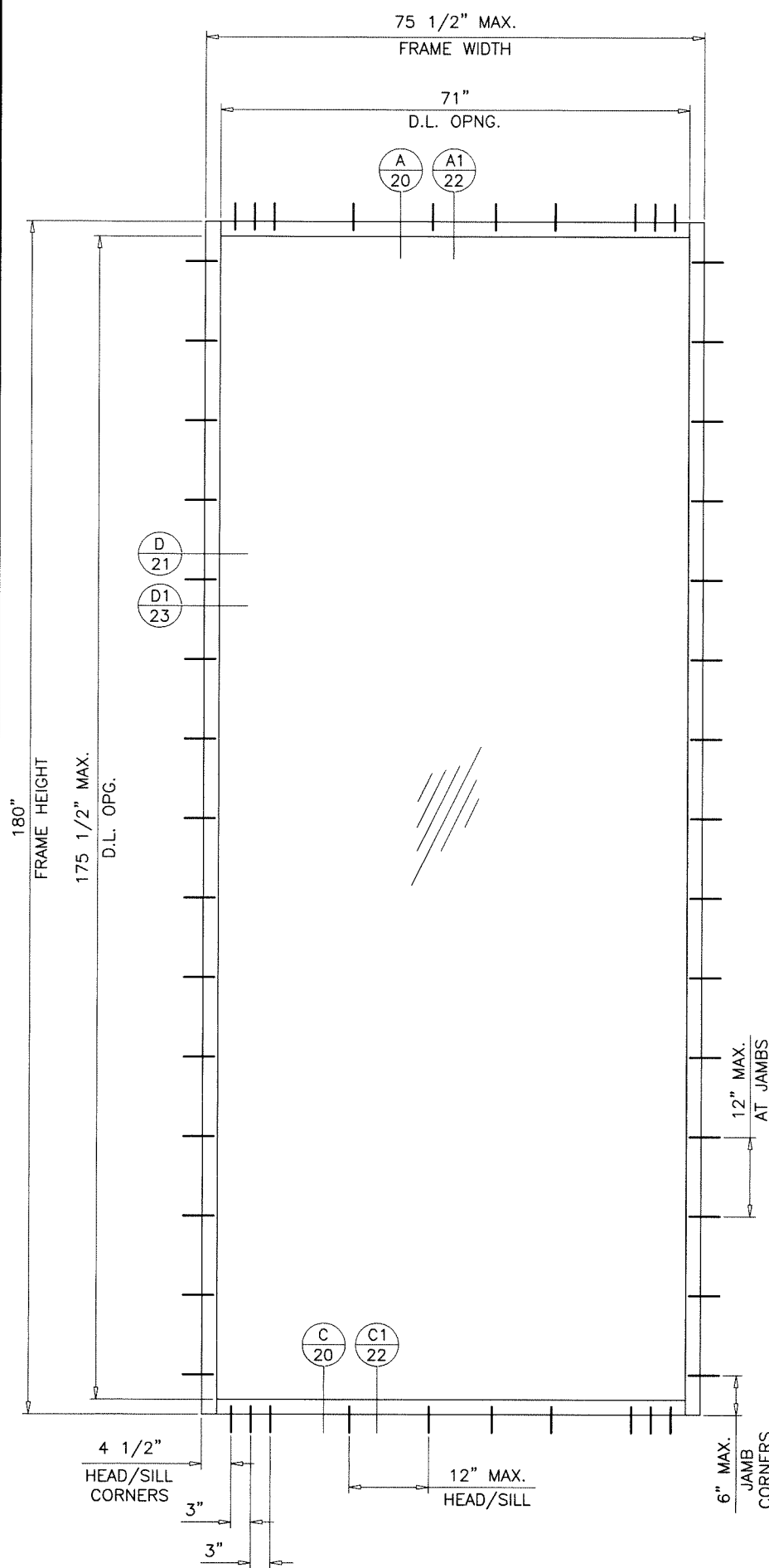

NOTE:  
GLASS CAPACITIES ON THIS SHEET ARE  
BASED ON ASTM E1300-09 (3 SEC. GUSTS).

DESIGN LOAD CAPACITY - PSF			
NOMINAL DIMS.		GLASS TYPE 'G'	
FRAME WIDTH	FRAME HEIGHT	EXT.(+)	INT.(-)
75-1/2"	114"	70.0	70.0
76-1/2"		69.0	69.0
79-1/2"		66.3	66.3
82-1/2"		63.7	63.7
85-1/2"		61.4	61.4
88-1/2"		59.2	59.2
91-1/2"		57.1	57.1
94-1/2"		55.2	55.2
97-1/2"		53.4	53.4
100-1/2"		51.8	51.8
103-1/2"		50.2	50.2
106-1/2"		48.7	48.7
109-1/2"	47.3	47.3	
112-1/2"	46.0	46.0	
75-1/2"	120"	70.0	70.0
76-1/2"		69.0	69.0
79-1/2"		66.3	66.3
82-1/2"		63.7	63.7
85-1/2"		61.4	61.4
88-1/2"		59.2	59.2
91-1/2"		57.1	57.1
94-1/2"		55.2	55.2
97-1/2"		53.4	53.4
100-1/2"		51.8	51.8
103-1/2"		50.2	50.2
106-1/2"		48.7	48.7
109-1/2"	47.3	47.3	
75-1/2"	126"	70.0	70.0
76-1/2"		69.0	69.0
79-1/2"		66.3	66.3
82-1/2"		63.7	63.7
85-1/2"		61.4	61.4
88-1/2"		59.2	59.2
91-1/2"		57.1	57.1
94-1/2"		55.2	55.2
97-1/2"		53.4	53.4
100-1/2"		51.8	51.8
103-1/2"		50.2	50.2
106-1/2"		48.7	48.7
75-1/2"	132"	70.0	70.0
76-1/2"		69.0	69.0
79-1/2"		66.3	66.3
82-1/2"		63.7	63.7
85-1/2"		61.4	61.4
88-1/2"		59.2	59.2
91-1/2"		57.1	57.1
94-1/2"		55.2	55.2
97-1/2"		53.4	53.4
100-1/2"		51.8	51.8

DESIGN LOAD CAPACITY - PSF				
NOMINAL DIMS.		GLASS TYPE 'G'		
FRAME WIDTH	FRAME HEIGHT	EXT.(+)	INT.(-)	
75-1/2"	138"	70.0	70.0	
76-1/2"		69.0	69.0	
79-1/2"		66.3	66.3	
82-1/2"		63.7	63.7	
85-1/2"		61.4	61.4	
88-1/2"		59.2	59.2	
91-1/2"	144"	57.1	57.1	
94-1/2"		55.2	55.2	
97-1/2"		53.4	53.4	
75-1/2"		150"	70.0	70.0
76-1/2"			69.0	69.0
79-1/2"			66.3	66.3
82-1/2"	63.7		63.7	
85-1/2"	61.4		61.4	
88-1/2"	59.2		59.2	
91-1/2"	156"	57.1	57.1	
94-1/2"		55.2	55.2	
97-1/2"		53.4	53.4	
75-1/2"		162"	70.0	70.0
76-1/2"			69.0	69.0
79-1/2"			66.3	66.3
82-1/2"	63.7		63.7	
85-1/2"	61.4		61.4	
88-1/2"	59.2		59.2	
91-1/2"	168"	57.1	57.1	
94-1/2"		55.2	55.2	
97-1/2"		53.4	53.4	
75-1/2"		174"	70.0	70.0
76-1/2"			69.0	69.0
79-1/2"			66.3	66.3
82-1/2"	63.7		63.7	
85-1/2"	61.4		61.4	
88-1/2"	59.2		59.2	
91-1/2"	180"	57.1	57.1	
94-1/2"		55.2	55.2	
97-1/2"		53.4	53.4	
100-1/2"		51.8	51.8	

INTERPOLATION BETWEEN WIDTHS OR HEIGHTS ALLOWED.

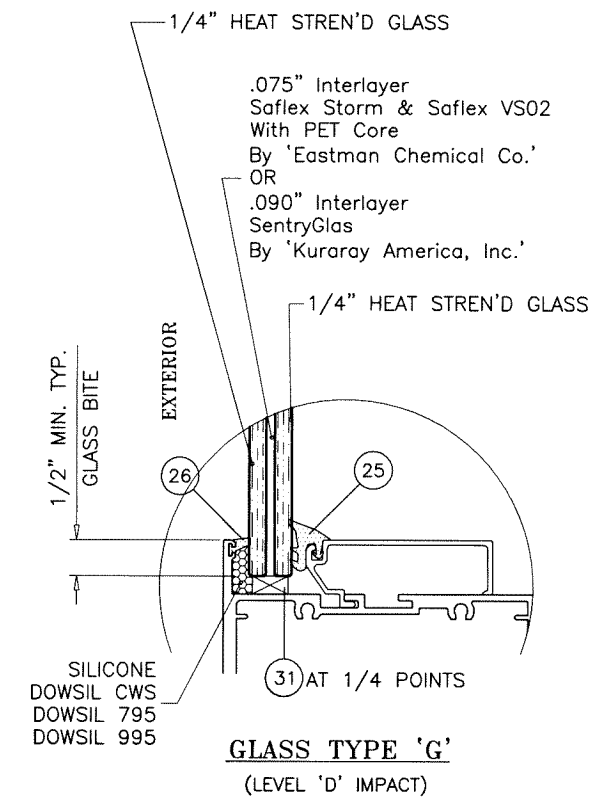

GLASS TYPE 'G'  
(LEVEL 'D' IMPACT)

GLASS  
(LEVEL 'D' IMPACT)

Sealed: 8/19/2025

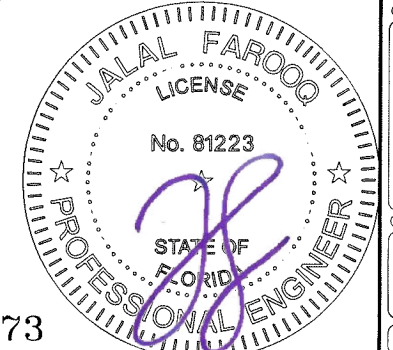

FL #19973

**af c**  
**AL-FAROOQ CORPORATION**  
ENGINEERS & PRODUCT DEVELOPMENT  
9360 SUNSET DRIVE, SUITE 220 (C.A.N. 3538)  
MIAMI, FLORIDA 33173  
TEL. (305) 264-8100 FAX. (305) 262-6978  
COMP-ANL\21-51FAGP

SERIES FRONT SET ALUM WINDOW WALL SYS. (L.M.I.)  
**Aldora Aluminum & Glass Products Inc.**  
4250 Coral Ridge Drive, Suite 101  
Coral Springs, FL 33065  
Tel. (954) 784-6900 Fax. (954) 784-6901

revisions:	no	date	by	description
date:	06-10-21	scale:	3/8" = 1"	
dr. by:	TARIQ	chk. by:		
drawing no.	21-51F			
sheet	5.1 of 27			

GLASS LOAD CAPACITY - PSF					
NOMINAL DIMS.		GLASS TYPE 'E'		GLASS TYPE 'Ei'	
D.L.O. WIDTH	D.L.O. HEIGHT	EXT.(+)	INT.(-)	EXT.(+)	INT.(-)
45"	109-1/2"	100.0	100.0	100.0	100.0
48"		100.0	100.0	100.0	100.0
51"		100.0	100.0	100.0	100.0
54"		100.0	100.0	100.0	100.0
57"		100.0	100.0	100.0	100.0
60"		95.2	95.2	95.2	95.2
63"		90.9	90.9	90.9	90.9
66"		87.0	87.0	87.0	87.0
69"		83.3	83.3	83.3	83.3
45"	115-1/2"	100.0	100.0	100.0	100.0
48"		100.0	100.0	100.0	100.0
51"		100.0	100.0	100.0	100.0
54"		100.0	100.0	100.0	100.0
57"		100.0	100.0	100.0	100.0
60"		95.2	95.2	95.2	95.2
63"		90.9	90.9	90.9	90.9
66"		87.0	87.0	87.0	87.0
69"		83.3	83.3	83.3	83.3
45"	121-1/2"	100.0	100.0	100.0	100.0
48"		100.0	100.0	100.0	100.0
51"		100.0	100.0	100.0	100.0
54"		100.0	100.0	100.0	100.0
57"		100.0	100.0	100.0	100.0
60"		95.2	95.2	95.2	95.2
63"	90.9	90.9	90.9	90.9	
45"	127-1/2"	100.0	100.0	100.0	100.0
48"		100.0	100.0	100.0	100.0
51"		100.0	100.0	100.0	100.0
54"		100.0	100.0	100.0	100.0
57"		98.2	98.2	100.0	100.0
60"		93.5	93.5	95.2	95.2
45"	133-1/2"	100.0	100.0	100.0	100.0
48"		100.0	100.0	100.0	100.0
51"		100.0	100.0	100.0	100.0
54"		100.0	100.0	100.0	100.0
57"		94.9	94.9	99.3	99.3
45"	139-1/2"	100.0	100.0	100.0	100.0
48"		100.0	100.0	100.0	100.0
51"		100.0	100.0	100.0	100.0
54"		97.5	97.5	100.0	100.0
57"		91.6	91.6	95.9	95.9

INTERPOLATION BETWEEN WIDTHS OR HEIGHTS ALLOWED.

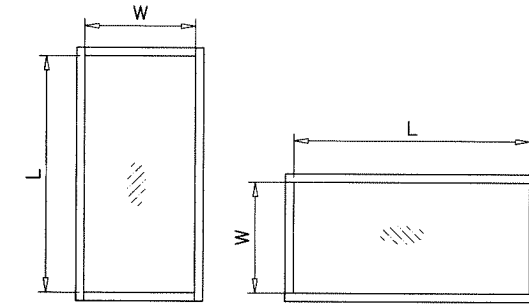
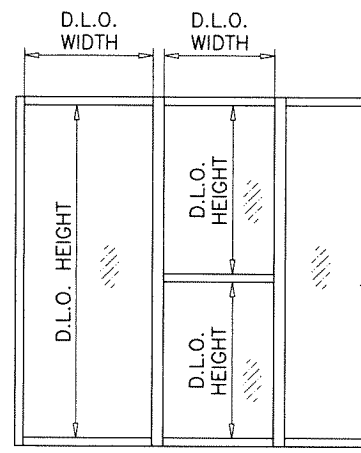

NOTE:  
WIDTH AND LENGTH DIMENSIONS  
CAN BE ORIENTED VERTICALLY OR  
HORIZONTALLY AS SHOWN ABOVE.

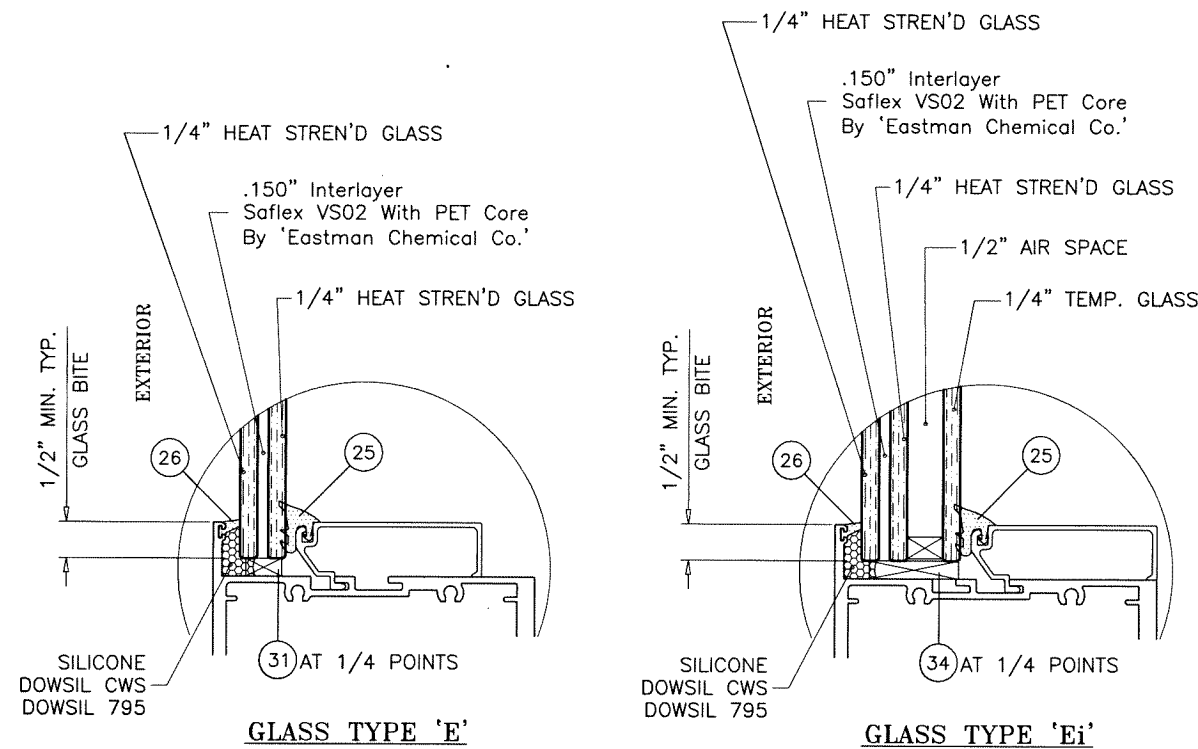

**GLAZING DETAILS LEVEL 'E' IMPACT**

NOTE:  
GLASS CAPACITIES ON THIS SHEET ARE  
BASED ON ASTM E1300-09 (3 SEC. GUSTS).

Sealed: 8/19/2025

**GLASS**  
(LEVEL 'E' IMPACT)



FL #19973

**af c**  
**AL-FAROOQ CORPORATION**  
ENGINEERS & PRODUCT DEVELOPMENT  
9360 SUNSET DRIVE, SUITE 220  
MIAMI, FLORIDA 33173 (C.A.N. 3538)  
TEL. (305) 264-8100 FAX. (305) 262-6978  
COMP-ANL 21-51FAGP

SERIES FRONT SET ALUM WINDOW WALL SYS. (L.M.I.)  
**Aldora Aluminum & Glass Products Inc.**  
4250 Coral Ridge Drive, Suite 101  
Coral Springs, FL. 33065  
Tel. (954) 784-6900 Fax. (954) 784-6901

revisions:	no	date	by	description
date:	06-10-21	scale:	3/8" = 1"	
dr. by:	TARIQ	chk. by:		
drawing no.	21-51F			
sheet	6 of 27			

GLASS LOAD CAPACITY - PSF			
NOMINAL DIMS.		GLASS TYPES 'F' & 'Fi'	
D.L.O. WIDTH	D.L.O. HEIGHT	EXT.(+)	INT.(-)
45"	91-1/2"	100.0	100.0
48"		100.0	100.0
51"		100.0	100.0
54"		100.0	100.0
57"		100.0	100.0
60"		95.2	95.2
63"		90.9	90.9
66"	87.0	87.0	
69"	83.3	83.3	
45"	103-1/2"	100.0	100.0
48"		100.0	100.0
51"		100.0	100.0
54"		100.0	100.0
57"		100.0	100.0
60"		95.2	95.2
63"		90.9	90.9
45"	115-1/2"	100.0	100.0
48"		100.0	100.0
51"		100.0	100.0
54"		100.0	100.0
57"		100.0	100.0
45"	127-1/2"	100.0	100.0
48"		100.0	100.0
51"		100.0	100.0
45"	139-1/2"	100.0	100.0

INTERPOLATION BETWEEN WIDTHS OR HEIGHTS ALLOWED.

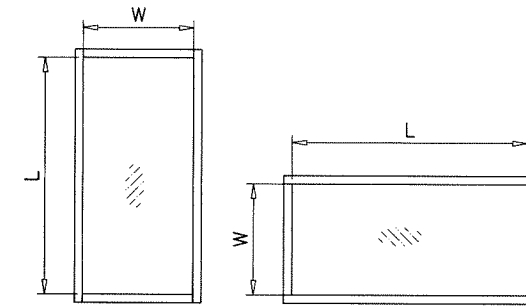
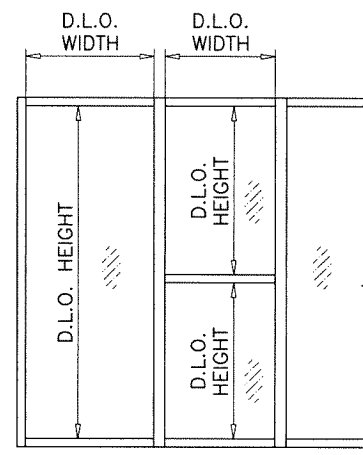

NOTE:  
WIDTH AND LENGTH DIMENSIONS  
CAN BE ORIENTED VERTICALLY OR  
HORIZONTALLY AS SHOWN ABOVE.

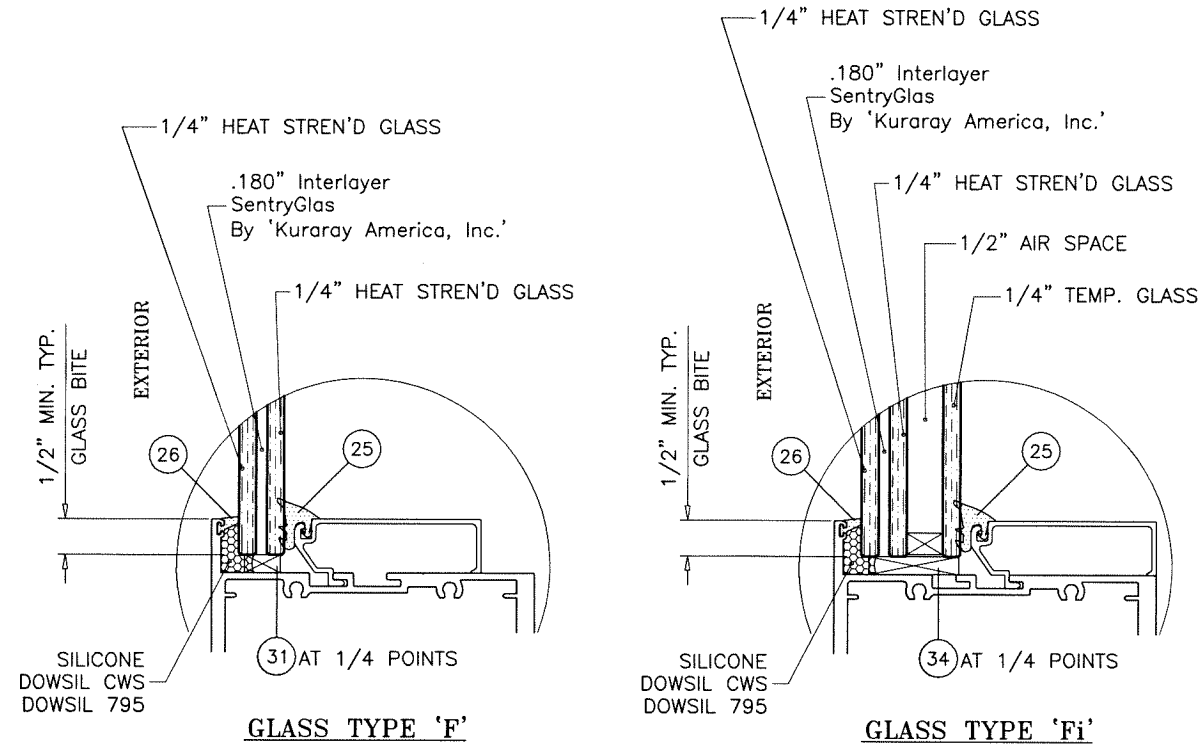

**GLAZING DETAILS LEVEL 'E' IMPACT**

NOTE:  
GLASS CAPACITIES ON THIS SHEET ARE  
BASED ON ASTM E1300-09 (3 SEC. GUSTS).

Sealed: 8/19/2025

**GLASS**  
(LEVEL 'E' IMPACT)

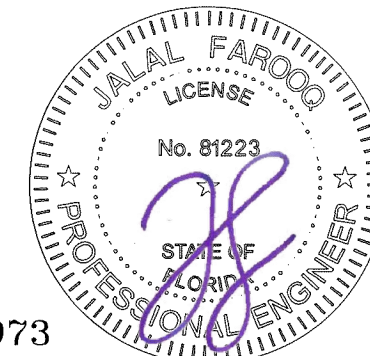

FL #19973

**af c**  
**AL-FAROOQ CORPORATION**  
ENGINEERS & PRODUCT DEVELOPMENT  
9360 SUNSET DRIVE, SUITE 220 (C.A.N. 3538)  
MIAMI, FLORIDA 33173  
TEL. (305) 264-8100 FAX. (305) 262-6978  
COMP-ANL 21-51FAGP

SERIES FRONT SET ALUM WINDOW WALL SYS. (L.M.I.)  
**Aldora Aluminum & Glass Products Inc.**  
4250 Coral Ridge Drive, Suite 101  
Coral Springs, FL. 33065  
Tel. (954) 784-6900 Fax. (954) 784-6901

revisions:	no	date	by	description

date: 06-10-21  
scale: 3/8" = 1"  
dr. by: TARIQ  
chk. by:

drawing no.  
**21-51F**  
sheet 6.1 of 27

DESIGN LOAD CAPACITY - PSF  
NON-THERMAL MULLION  
WITHOUT INTERMEDIATE HORIZONTALS

NOMINAL DIMS.		JAMBS 'J1' & 'J5' MULLION 'M1'	
WIDTH (W)	FRAME HEIGHT	EXT.(+)	INT.(-)
30"	84"	90.0	90.0
36"		90.0	90.0
42"		90.0	90.0
48"		90.0	90.0
54"		90.0	90.0
60"		90.0	90.0
61"		90.0	90.0
66"		80.0	80.0
72"	80.0	80.0	
30"	90"	90.0	90.0
36"		90.0	90.0
42"		90.0	90.0
48"		90.0	90.0
54"		90.0	90.0
57"		88.6	88.6
60"		80.0	80.0
66"		80.0	80.0
72"	77.3	77.3	
30"	96"	90.0	90.0
36"		90.0	90.0
42"		90.0	90.0
48"		86.7	86.7
54"		78.9	78.9
60"		73.1	73.1
66"		68.6	68.6
72"		65.3	65.3
30"	102"	90.0	90.0
36"		90.0	90.0
42"		84.4	84.4
48"		75.4	75.4
50"		72.9	72.9
54"		68.5	68.5
60"		63.2	63.2
66"		59.0	59.0
70"	56.8	56.8	
30"	108"	90.0	90.0
36"		80.9	80.9
42"		70.5	70.5
48"		62.9	62.9
54"		57.2	57.2
60"		52.8	52.8
66"		49.4	49.4
30"		114"	81.2
36"	68.5		68.5
42"	59.6		59.6
48"	53.1		53.1
54"	48.1		48.1
60"	44.3		44.3
63"	42.7		42.7
30"	120"		69.4
36"		58.5	58.5
42"		50.8	50.8
48"		45.2	45.2
54"		40.9	40.9
60"		37.5	37.5

INTERPOLATION BETWEEN WIDTHS OR HEIGHTS ALLOWED.

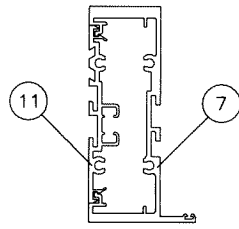

JAMB 'J1'  
(LEVEL 'D' IMPACT)  
Ix IN<sup>4</sup> Sx IN<sup>3</sup>  
5.684 2.521

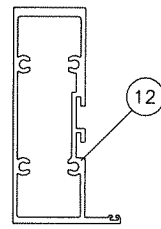

JAMB 'J5'  
(LEVEL 'D' IMPACT)  
Ix IN<sup>4</sup> Sx IN<sup>3</sup>  
4.027 1.788

FOR UNSECURED (UNANCHORED) JAMB 'J5'  
LIMIT MAX. DESIGN LOAD TO ±65.0 PSF

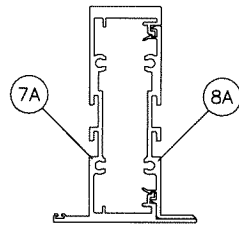

MULLION 'M1'  
(LEVEL 'D' IMPACT)  
Ix IN<sup>4</sup> Sx IN<sup>3</sup>  
5.670 2.514

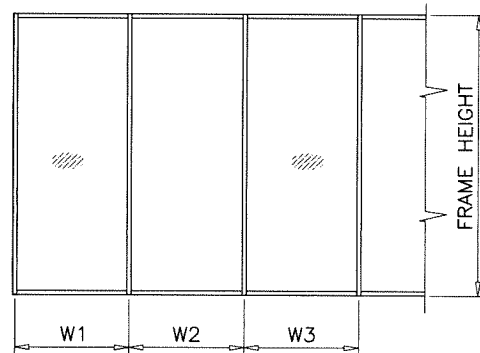
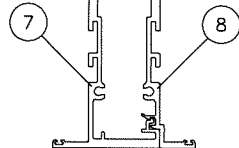

WIDTH (W) = W1  
AT FRAME JAMB

WIDTH (W) =  $\frac{W2 + W3}{2}$   
AT FRAME MULLION

NOTE:  
JAMBS 'J1', 'J5' AND 'J3' MAY BE SECURED (ANCHORED)  
OR UNSECURED (UNANCHORED)  
FOR SECURED JAMBS, USE ANCHOR SPACING  
SHOWN ON SHEET 1.  
FOR UNSECURED JAMBS VERIFY MAX. GAPS ON  
SHEETS 21 OR 23.

DESIGN LOAD CAPACITY - PSF  
THERMAL MULLION  
WITHOUT INTERMEDIATE HORIZONTALS

NOMINAL DIMS.		JAMB 'J3' MULLION 'M3'	
WIDTH (W)	FRAME HEIGHT	EXT.(+)	INT.(-)
30"	84"	90.0	90.0
36"		90.0	90.0
42"		90.0	90.0
48"		90.0	90.0
54"		90.0	90.0
60"		80.0	80.0
66"		80.0	80.0
72"		80.0	80.0
30"	90"	90.0	90.0
36"		90.0	90.0
42"		90.0	90.0
48"		90.0	90.0
51"		90.0	90.0
54"		80.0	80.0
60"		80.0	80.0
66"		80.0	80.0
72"	77.9	77.9	
30"	96"	90.0	90.0
36"		90.0	90.0
42"		90.0	90.0
48"		87.3	87.3
54"		79.5	79.5
60"		73.6	73.6
66"		69.1	69.1
72"		65.7	65.7
30"	102"	80.0	80.0
36"		80.0	80.0
42"		80.0	80.0
48"		75.9	75.9
54"		68.9	68.9
60"		63.6	63.6
66"		59.4	59.4
70"		57.2	57.2
30"	108"	80.0	80.0
36"		80.0	80.0
42"		72.3	72.3
48"		64.5	64.5
54"		58.7	58.7
60"		54.2	54.2
66"		50.7	50.7
30"		114"	80.0
36"	70.2		70.2
42"	61.1		61.1
48"	54.4		54.4
54"	49.3		49.3
60"	45.4		45.4
63"	43.8		43.8
30"	120"		71.2
36"		60.0	60.0
42"		52.1	52.1
48"		46.3	46.3
54"		41.9	41.9
60"		38.5	38.5

INTERPOLATION BETWEEN WIDTHS OR HEIGHTS ALLOWED.

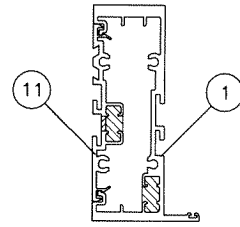

JAMB 'J3'  
(LEVEL 'D' IMPACT)  
Ix IN<sup>4</sup> Sx IN<sup>3</sup>  
5.813 2.538

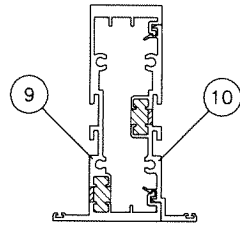

MULLION 'M3'  
(LEVEL 'D' IMPACT)  
Ix IN<sup>4</sup> Sx IN<sup>3</sup>  
5.813 2.529

JAMB & MULLIONS  
(LEVEL 'D' IMPACT)  
WITHOUT HORIZONTALS

Sealed: 8/19/2025

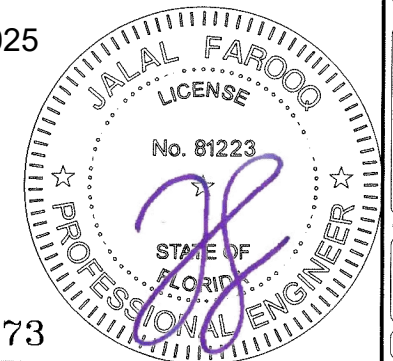

FL #19973

**af c**  
**AL-FAROOQ CORPORATION**  
ENGINEERS & PRODUCT DEVELOPMENT  
9360 SUNSET DRIVE, SUITE 220  
MIAMI, FLORIDA 33173 (C.A.N. 3538)  
TEL. (305) 264-8100 FAX. (305) 262-6978  
COMP-ANL\21-51FAGP

SERIES FRONT SET ALUM WINDOW WALL SYS. (L.M.I.)  
**Aldora Aluminum & Glass Products Inc.**  
4250 Coral Ridge Drive, Suite 101  
Coral Springs, FL. 33065  
Tel. (954) 784-6900 Fax. (954) 784-6901

revisions:	no	date	by	description

date: 06-10-21	scale: -	dr. by: TARIQ	chk. by:
----------------	----------	---------------	----------

drawing no.  
**21-51F**  
sheet 7 of 27

DESIGN LOAD CAPACITY - PSF THERMAL MULLION WITHOUT INTERMEDIATE HORIZONTALS			
NOMINAL DIMS.		JAMB 'J4' MULLION 'M4'	
WIDTH (W)	FRAME HEIGHT	EXT.(+)	INT.(-)
30"	84"	100.0	100.0
36"		100.0	100.0
42"		100.0	100.0
48"		100.0	100.0
54"		100.0	100.0
60"		100.0	100.0
66"		60.0	60.0
72"		60.0	60.0
30"	90"	100.0	100.0
36"		100.0	100.0
42"		100.0	100.0
48"		100.0	100.0
54"		100.0	100.0
56"		100.0	100.0
60"		60.0	60.0
66"		60.0	60.0
72"	60.0	60.0	
30"	96"	100.0	100.0
36"		100.0	100.0
42"		100.0	100.0
48"		100.0	100.0
52"		100.0	100.0
54"		60.0	60.0
60"		60.0	60.0
66"		60.0	60.0
72"	60.0	60.0	
30"	102"	100.0	100.0
39"		100.0	100.0
42"		100.0	100.0
48"		100.0	100.0
49"		100.0	100.0
54"		60.0	60.0
60"		60.0	60.0
66"		60.0	60.0
72"	60.0	60.0	
30"	108"	100.0	100.0
36"		100.0	100.0
42"		100.0	100.0
46"		99.2	99.2
48"		60.0	60.0
54"		60.0	60.0
60"		60.0	60.0
66"		60.0	60.0
72"	60.0	60.0	
30"	114"	100.0	100.0
36"		100.0	100.0
42"		96.0	96.0
44"		92.0	92.0
48"		60.0	60.0
54"		60.0	60.0
60"		60.0	60.0
66"		60.0	60.0
72"	60.0	60.0	

DESIGN LOAD CAPACITY - PSF THERMAL MULLION WITHOUT INTERMEDIATE HORIZONTALS			
NOMINAL DIMS.		JAMB 'J4' MULLION 'M4'	
WIDTH (W)	FRAME HEIGHT	EXT.(+)	INT.(-)
30"	120"	100.0	100.0
36"		99.5	99.5
42"		86.2	86.2
48"		60.0	60.0
54"		60.0	60.0
60"		60.0	60.0
66"		58.5	58.5
72"		54.8	54.8
30"	126"	60.0	60.0
36"		60.0	60.0
42"		60.0	60.0
48"		60.0	60.0
54"		60.0	60.0
60"		56.7	56.7
66"		52.5	52.5
72"		49.0	49.0
30"	132"	60.0	60.0
36"		60.0	60.0
42"		60.0	60.0
48"		60.0	60.0
54"		56.3	56.3
60"		51.3	51.3
65"		48.0	48.0
30"		138"	60.0
36"	60.0		60.0
42"	60.0		60.0
48"	57.0		57.0
54"	51.2		51.2
60"	46.7		46.7
62"	45.4		45.4
30"	144"		60.0
36"		60.0	60.0
42"		59.0	59.0
48"		52.2	52.2
54"		46.9	46.9
60"		42.6	42.6

INTERPOLATION BETWEEN WIDTHS OR HEIGHTS ALLOWED.

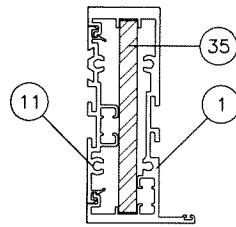

JAMB 'J4'  
(LEVEL 'D' IMPACT)

	Ix IN <sup>4</sup>	Sx IN <sup>3</sup>
ALUMINUM	5.813	2.538
STEEL	2.000	1.000
TOTAL	11.613	
Ix ALUM + Ix STL X 2.9	11.613	

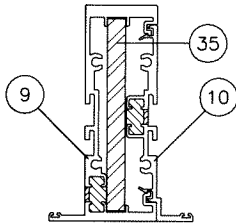

MULLION 'M4'  
(LEVEL 'D' IMPACT)

	Ix IN <sup>4</sup>	Sx IN <sup>3</sup>
ALUMINUM	5.813	2.529
STEEL	2.000	1.000
TOTAL	11.613	
Ix ALUM + Ix STL X 2.9	11.613	

NOTE:  
JAMB 'J4' MAY BE SECURED (ANCHORED)  
OR UNSECURED (UNANCHORED)  
FOR SECURED JAMBS, USE ANCHOR SPACING  
SHOWN ON SHEET 1.  
FOR UNSECURED JAMBS VERIFY MAX. GAPS ON  
SHEETS 21 OR 23.

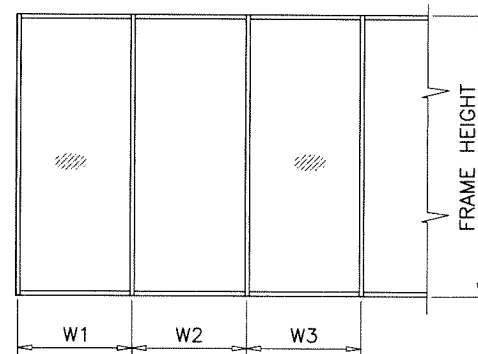

WIDTH (W) = W1  
AT FRAME JAMB

WIDTH (W) =  $\frac{W2 + W3}{2}$   
AT FRAME MULLION

JAMB & MULLIONS  
(LEVEL 'D' IMPACT)  
WITHOUT HORIZONTALS

Sealed: 8/19/2025

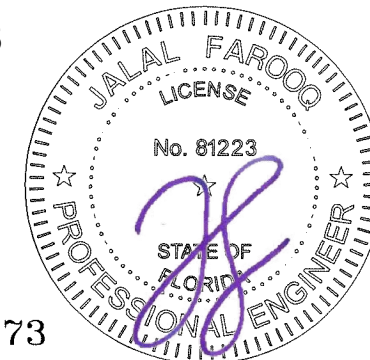

FL #19973

**AL-FAROOQ CORPORATION**  
ENGINEERS & PRODUCT DEVELOPMENT  
9360 SUNSET DRIVE, SUITE 220  
MIAMI, FLORIDA 33173 (C.A.N. 3538)  
TEL. (305) 264-8100 FAX. (305) 262-6978  
COMP-ANL\21-51FAGP

SERIES FRONT SET ALUM WINDOW WALL SYS. (L.M.I.)  
**Adora Aluminum & Glass Products Inc.**  
4250 Coral Ridge Drive, Suite 101  
Coral Springs, FL 33065  
Tel. (954) 784-6900 Fax. (954) 784-6901

no	date	by	description

date: 06-10-21  
scale: -  
dr. by: TARIQ  
chk. by:

drawing no.  
**21-51F**  
sheet 8 of 27

DESIGN LOAD CAPACITY - PSF NON-THERMAL MULLION WITHOUT INTERMEDIATE HORIZONTALS			
NOMINAL DIMS.		JAMB 'J5' MULLION 'M1'	
WIDTH (W)	FRAME HEIGHT	EXT.(+)	INT.(-)
30"	84"	90.0	90.0
36"		90.0	90.0
42"		90.0	90.0
48"		90.0	90.0
54"		90.0	90.0
57"		90.0	90.0
30"	90"	90.0	90.0
36"		90.0	90.0
42"		90.0	90.0
48"		90.0	90.0
53-1/2"		90.0	90.0

INTERPOLATION BETWEEN WIDTHS OR HEIGHTS ALLOWED.

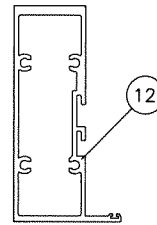

JAMB 'J5'  
(LEVEL 'D' & 'E' IMPACT)

Ix IN <sup>4</sup>	Sx IN <sup>3</sup>
4.027	1.788

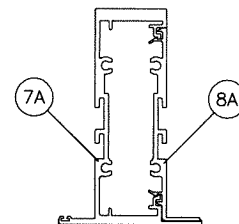

MULLION 'M1'  
(LEVEL 'D' & 'E' IMPACT)

Ix IN <sup>4</sup>	Sx IN <sup>3</sup>
5.670	2.514

NOTE:  
JAMB 'J5' MAY BE SECURED (ANCHORED)  
OR UNSECURED (UNANCHORED)  
FOR SECURED JAMBS, USE ANCHOR SPACING  
SHOWN ON SHEET 1.  
FOR UNSECURED JAMBS VERIFY MAX. GAPS ON  
SHEETS 21 OR 23.

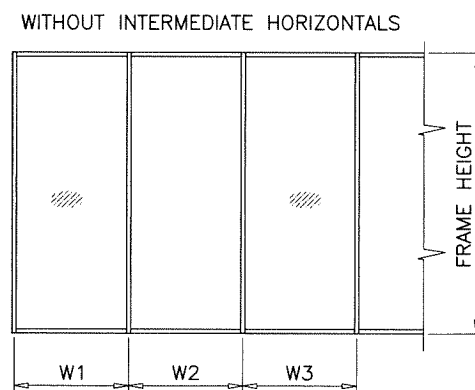

WIDTH (W) = W1  
AT FRAME JAMB

WIDTH (W) =  $\frac{W2 + W3}{2}$   
AT FRAME MULLION

DESIGN LOAD CAPACITY - PSF NON-THERMAL MULLION WITHOUT INTERMEDIATE HORIZONTALS			
NOMINAL DIMS.		JAMB 'J2'/'J2A' MULLION 'M2'	
WIDTH (W)	FRAME HEIGHT	EXT.(+)	INT.(-)
30"	84"	120.0	135.0
36"		120.0	135.0
42"		120.0	135.0
48"		120.0	135.0
54"		120.0	135.0
60"		120.0	135.0
66"		100.0	100.0
72"		100.0	100.0
30"	90"	120.0	135.0
36"		120.0	135.0
42"		120.0	135.0
48"		120.0	135.0
54"		120.0	135.0
56"		120.0	135.0
60"		100.0	100.0
66"		100.0	100.0
72"	100.0	100.0	
30"	96"	120.0	135.0
36"		120.0	135.0
42"		120.0	135.0
48"		120.0	135.0
52"		120.0	135.0
54"		100.0	100.0
60"		100.0	100.0
66"		100.0	100.0
72"	100.0	100.0	
30"	102"	120.0	135.0
39"		120.0	135.0
42"		120.0	135.0
48"		120.0	135.0
49"		120.0	135.0
54"		100.0	100.0
60"		100.0	100.0
66"		100.0	100.0
72"	100.0	100.0	
30"	108"	120.0	135.0
36"		120.0	135.0
42"		120.0	135.0
46"		120.0	135.0
48"		100.0	100.0
54"		100.0	100.0
60"		100.0	100.0
66"		100.0	100.0
72"	100.0	100.0	
30"	114"	120.0	135.0
36"		120.0	135.0
42"		120.0	135.0
44"		120.0	135.0
48"		100.0	100.0
54"		100.0	100.0
60"		100.0	100.0
66"		96.8	96.8
72"	90.9	90.9	

DESIGN LOAD CAPACITY - PSF NON-THERMAL MULLION WITHOUT INTERMEDIATE HORIZONTALS			
NOMINAL DIMS.		JAMB 'J2'/'J2A' MULLION 'M2'	
WIDTH (W)	FRAME HEIGHT	EXT.(+)	INT.(-)
30"	120"	120.0	135.0
36"		120.0	135.0
42"		120.0	128.0
48"		100.0	100.0
54"		100.0	100.0
60"		93.1	93.1
66"		86.3	86.3
72"		80.8	80.8
30"	126"	100.0	100.0
36"		100.0	100.0
42"		100.0	100.0
48"		100.0	100.0
54"		91.6	91.6
60"		83.7	83.7
66"		77.4	77.4
68"		75.6	75.6
30"	132"	100.0	100.0
36"		100.0	100.0
42"		100.0	100.0
48"		92.3	92.3
54"		83.0	83.0
60"		75.7	75.7
65"		70.8	70.8
30"		138"	100.0
36"	100.0		100.0
42"	95.3		95.3
48"	84.1		84.1
54"	75.6		75.6
60"	68.9		68.9
62"	67.0		67.0
30"	144"		100.0
36"		100.0	100.0
42"		87.1	87.1
48"		77.0	77.0
54"		69.1	69.1
60"		62.9	62.9

INTERPOLATION BETWEEN WIDTHS OR HEIGHTS ALLOWED.

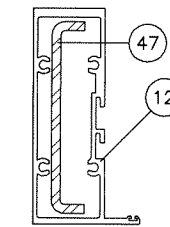

JAMB 'J2'  
(LEVEL 'D' & 'E' IMPACT)

	Ix IN <sup>4</sup>	Sx IN <sup>3</sup>
ALUMINUM	4.027	1.788
STEEL	1.566	.783
TOTAL	8.523	
Ix ALUM + Ix STL X 2.9		

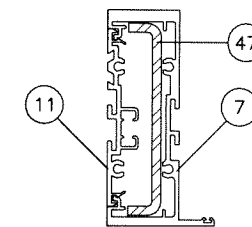

JAMB 'J2A'  
(LEVEL 'D' & 'E' IMPACT)

	Ix IN <sup>4</sup>	Sx IN <sup>3</sup>
ALUMINUM	5.684	2.521
STEEL	1.566	.783
TOTAL	10.180	
Ix ALUM + Ix STL X 2.9		

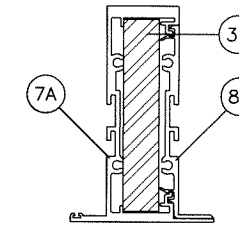

MULLION 'M2'  
(LEVEL 'D' & 'E' IMPACT)

	Ix IN <sup>4</sup>	Sx IN <sup>3</sup>
ALUMINUM	5.670	2.514
STEEL	4.000	2.000
TOTAL	17.270	
Ix ALUM + Ix STL X 2.9		

NOTE:  
JAMBS 'J2' AND 'J2A' MAY BE SECURED (ANCHORED)  
OR UNSECURED (UNANCHORED)  
FOR SECURED JAMBS, USE ANCHOR SPACING  
SHOWN ON SHEET 1.  
FOR UNSECURED JAMBS VERIFY MAX. GAPS ON  
SHEETS 21 OR 23.

JAMB & MULLIONS  
(LEVEL 'D' & 'E' IMPACT)  
WITHOUT HORIZONTALS

Sealed: 8/19/2025

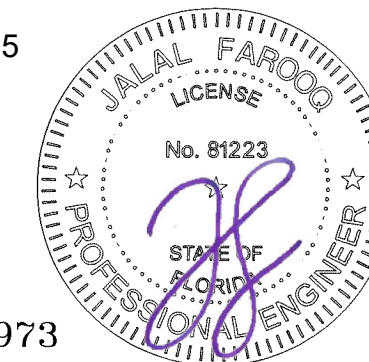

FL #19973

**a f c**  
**AL-FAROOQ CORPORATION**  
ENGINEERS & PRODUCT DEVELOPMENT  
9360 SUNSET DRIVE, SUITE 220  
MIAMI, FLORIDA 33173 (C.A.N. 3538)  
TEL. (305) 262-6978  
FAX. (305) 262-6978

SERIES FRONT SET ALUM WINDOW WALL SYS. (L.M.I.)  
**Aldora Aluminum & Glass Products Inc.**  
4250 Coral Ridge Drive, Suite 101  
Coral Springs, FL 33065  
Tel. (954) 784-6900 Fax. (954) 784-6901

revisions:	no.	date	by	description

date:	06-10-21
scale:	-
dr. by:	TARIQ
chk. by:	

drawing no.  
**21-51F**  
sheet 8.1 of 27

COMP-ANL\21-51FAGP

DESIGN LOAD CAPACITY - PSF NON-THERMAL MULLION WITH INTERMEDIATE HORIZONTALS			
NOMINAL DIMS.		JAMBS 'J1' & 'J5' MULLION 'M1'	
WIDTH (W)	FRAME HEIGHT	EXT.(+)	INT.(-)
30"	84"	90.0	90.0
36"		90.0	90.0
42"		90.0	90.0
48"		90.0	90.0
54"		90.0	90.0
60"		84.5	84.5
61"		83.1	83.1
66"		76.8	76.8
72"	70.4	70.4	
30"	90"	90.0	90.0
36"		90.0	90.0
42"		90.0	90.0
48"		90.0	90.0
54"		81.2	81.2
57"		76.9	76.9
60"		73.0	73.0
66"		66.4	66.4
72"	60.9	60.9	
30"	96"	90.0	90.0
36"		90.0	90.0
42"		91.0	91.0
48"		79.6	79.6
54"		70.8	70.8
60"		63.7	63.7
66"		57.9	57.9
72"		53.1	53.1
30"	102"	90.0	90.0
36"		90.0	90.0
42"		78.9	78.9
48"		69.1	69.1
50"		66.3	66.3
54"		61.4	61.4
60"		55.3	55.3
66"		50.2	50.2
70"	47.4	47.4	
30"	108"	90.0	90.0
36"		77.6	77.6
42"		66.5	66.5
48"		58.2	58.2
54"		51.7	51.7
60"		46.6	46.6
66"		42.3	42.3
30"		114"	79.2
36"	66.0		66.0
42"	56.5		56.5
48"	49.5		49.5
54"	44.0		44.0
60"	39.6		39.6
63"	37.7		37.7
30"	120"		67.9
36"		56.6	56.6
42"		48.5	48.5
48"		42.4	42.4
54"		37.7	37.7
60"		33.9	33.9

INTERPOLATION BETWEEN WIDTHS OR HEIGHTS ALLOWED.

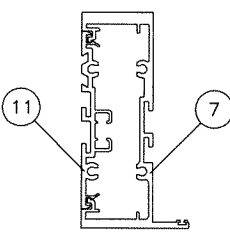

**JAMB 'J1'**  
(LEVEL 'D' IMPACT)  
Ix IN<sup>4</sup> Sx IN<sup>3</sup>  
5.684 2.521

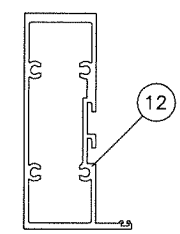

**JAMB 'J5'**  
(LEVEL 'D' IMPACT)  
Ix IN<sup>4</sup> Sx IN<sup>3</sup>  
4.027 1.788

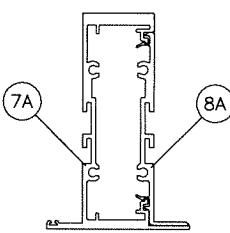

**MULLION 'M1'**  
(LEVEL 'D' IMPACT)  
Ix IN<sup>4</sup> Sx IN<sup>3</sup>  
5.670 2.514

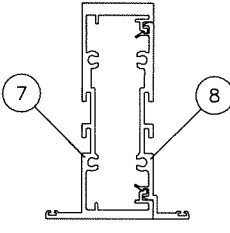

**MULLION 'M3'**  
(LEVEL 'D' IMPACT)  
Ix IN<sup>4</sup> Sx IN<sup>3</sup>  
5.813 2.529

NOTE:  
JAMBS 'J1', 'J5' AND 'J3' MAY BE SECURED (ANCHORED)  
OR UNSECURED (UNANCHORED)  
FOR SECURED JAMBS, USE ANCHOR SPACING  
SHOWN ON SHEET 1.  
FOR UNSECURED JAMBS VERIFY MAX. GAPS ON  
SHEETS 21 OR 23.

FOR UNSECURED (UNANCHORED) JAMB 'J5'  
LIMIT MAX. DESIGN LOAD TO ±65.0 PSF

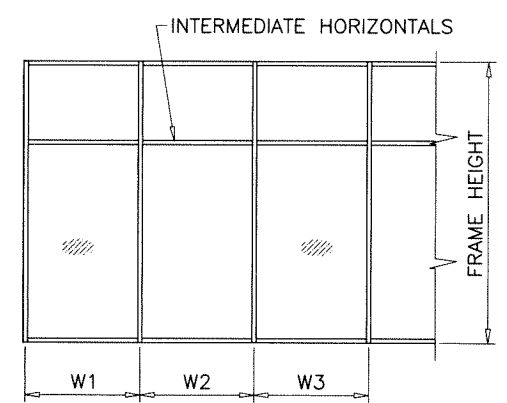

WIDTH (W) = W1  
AT FRAME JAMB

WIDTH (W) =  $\frac{W2 + W3}{2}$   
AT FRAME MULLION

DESIGN LOAD CAPACITY - PSF THERMAL MULLION WITH INTERMEDIATE HORIZONTALS			
NOMINAL DIMS.		JAMB 'J3' MULLION 'M3'	
WIDTH (W)	FRAME HEIGHT	EXT.(+)	INT.(-)
30"	84"	90.0	90.0
36"		90.0	90.0
42"		90.0	90.0
48"		90.0	90.0
54"		90.0	90.0
60"		85.1	85.1
66"		77.3	77.3
72"		70.9	70.9
30"	90"	90.0	90.0
36"		90.0	90.0
42"		90.0	90.0
48"		90.0	90.0
51"		86.5	86.5
54"		81.7	81.7
60"		73.5	73.5
66"		66.8	66.8
72"	61.3	61.3	
30"	96"	90.0	90.0
36"		90.0	90.0
42"		90.0	90.0
48"		80.2	80.2
54"		71.2	71.2
60"		64.1	64.1
66"		58.3	58.3
72"		53.4	53.4
30"	102"	80.0	80.0
36"		80.0	80.0
42"		80.0	80.0
48"		70.5	70.5
54"		62.6	62.6
60"		56.4	56.4
66"		51.2	51.2
70"		48.3	48.3
30"	108"	80.0	80.0
36"		79.5	79.5
42"		68.2	68.2
48"		59.7	59.7
54"		53.0	53.0
60"		47.7	47.7
66"		43.4	43.4
30"		114"	80.0
36"	67.6		67.6
42"	58.0		58.0
48"	50.7		50.7
54"	45.1		45.1
60"	40.6		40.6
63"	38.6		38.6
30"	120"		69.6
36"		58.0	58.0
42"		49.7	49.7
48"		43.5	43.5
54"		38.7	38.7
60"		34.8	34.8

INTERPOLATION BETWEEN WIDTHS OR HEIGHTS ALLOWED.

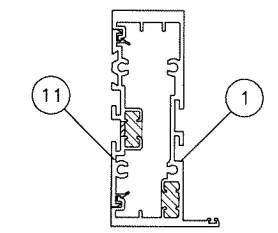

**JAMB 'J3'**  
(LEVEL 'D' IMPACT)  
Ix IN<sup>4</sup> Sx IN<sup>3</sup>  
5.813 2.538

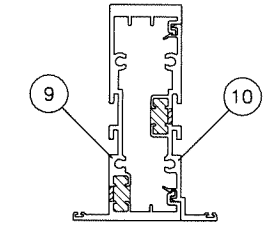

**MULLION 'M3'**  
(LEVEL 'D' IMPACT)  
Ix IN<sup>4</sup> Sx IN<sup>3</sup>  
5.813 2.529

**JAMB & MULLIONS**  
(LEVEL 'D' IMPACT)  
WITH HORIZONTALS

Sealed: 8/19/2025

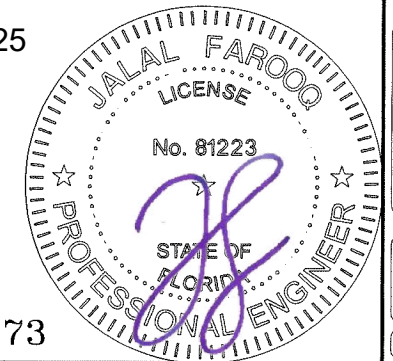

FL #19973

**af c**  
**AL-FAROOQ CORPORATION**  
ENGINEERS & PRODUCT DEVELOPMENT  
9360 SUNSET DRIVE, SUITE 220  
MIAMI, FLORIDA 33173 (C.A.N. 3538)  
TEL. (305) 264-8100 FAX. (305) 262-6978  
COMP-ANL\21-51FAGP

SERIES FRONT SET ALUM WINDOW WALL SYS. (L.M.I.)  
**Aldora Aluminum & Glass Products Inc.**  
4250 Coral Ridge Drive, Suite 101  
Coral Springs, FL. 33065  
Tel. (954) 784-6900 Fax. (954) 784-6901

revisions:	no.	date	by	description
date:	06-10-21	scale:		
dr. by:	TARIO	chk. by:		
drawing no.	21-51F			
sheet	9 of 27			

DESIGN LOAD CAPACITY - PSF THERMAL MULLION WITH INTERMEDIATE HORIZONTALS			
NOMINAL DIMS.		JAMB 'J4' MULLION 'M4'	
WIDTH (W)	FRAME HEIGHT	EXT.(+)	INT.(-)
30"	84"	100.0	100.0
36"		100.0	100.0
42"		100.0	100.0
48"		100.0	100.0
54"		100.0	100.0
60"		100.0	100.0
66"		60.0	60.0
72"		60.0	60.0
30"	90"	100.0	100.0
36"		100.0	100.0
42"		100.0	100.0
48"		100.0	100.0
54"		100.0	100.0
56"		100.0	100.0
60"		60.0	60.0
66"		60.0	60.0
72"	60.0	60.0	
30"	96"	100.0	100.0
36"		100.0	100.0
42"		100.0	100.0
48"		100.0	100.0
52"		100.0	100.0
54"		60.0	60.0
60"		60.0	60.0
66"		60.0	60.0
72"	60.0	60.0	
30"	102"	100.0	100.0
39"		100.0	100.0
42"		100.0	100.0
48"		100.0	100.0
49"		98.2	98.2
54"		60.0	60.0
60"		60.0	60.0
66"		60.0	60.0
72"	60.0	60.0	
30"	108"	100.0	100.0
36"		100.0	100.0
42"		100.0	100.0
46"		93.3	93.3
48"		60.0	60.0
54"		60.0	60.0
60"		60.0	60.0
66"		60.0	60.0
72"	59.6	59.6	
30"	114"	100.0	100.0
36"		100.0	100.0
42"		91.7	91.7
44"		87.6	87.6
48"		60.0	60.0
54"		60.0	60.0
60"		60.0	60.0
66"		58.4	58.4
72"	53.5	53.5	

DESIGN LOAD CAPACITY - PSF THERMAL MULLION WITH INTERMEDIATE HORIZONTALS			
NOMINAL DIMS.		JAMB 'J4' MULLION 'M4'	
WIDTH (W)	FRAME HEIGHT	EXT.(+)	INT.(-)
30"	120"	100.0	100.0
36"		96.6	96.6
42"		82.8	82.8
48"		60.0	60.0
54"		60.0	60.0
60"		58.0	58.0
66"		52.7	52.7
72"		48.3	48.3
30"	126"	60.0	60.0
36"		60.0	60.0
42"		60.0	60.0
48"		60.0	60.0
54"		58.4	58.4
60"		52.6	52.6
66"		47.8	47.8
72"		46.4	46.4
30"	132"	60.0	60.0
36"		60.0	60.0
42"		60.0	60.0
48"		59.9	59.9
54"		53.2	53.2
60"		47.9	47.9
65"		44.2	44.2
30"		138"	60.0
36"	60.0		60.0
42"	60.0		60.0
48"	54.8		54.8
54"	48.7		48.7
60"	43.8		43.8
62"	42.4		42.4
30"	144"		60.0
36"		60.0	60.0
42"		57.2	57.2
48"		50.0	50.0
54"		44.5	44.5
60"		40.0	40.0

INTERPOLATION BETWEEN WIDTHS OR HEIGHTS ALLOWED.

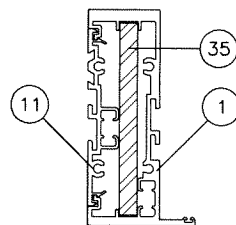

JAMB 'J4'  
(LEVEL 'D' IMPACT)

	Ix IN <sup>4</sup>	Sx IN <sup>3</sup>
ALUMINUM	5.813	2.538
STEEL	2.000	1.000
TOTAL		
Ix ALUM + Ix STL X 2.9	11.613	

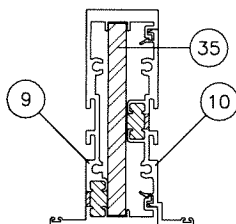

MULLION 'M4'  
(LEVEL 'D' IMPACT)

	Ix IN <sup>4</sup>	Sx IN <sup>3</sup>
ALUMINUM	5.813	2.529
STEEL	2.000	1.000
TOTAL		
Ix ALUM + Ix STL X 2.9	11.613	

NOTE:  
JAMB 'J4' MAY BE SECURED (ANCHORED)  
OR UNSECURED (UNANCHORED)  
FOR SECURED JAMBS, USE ANCHOR SPACING  
SHOWN ON SHEET 1.  
FOR UNSECURED JAMBS VERIFY MAX. GAPS ON  
SHEETS 21 OR 23.

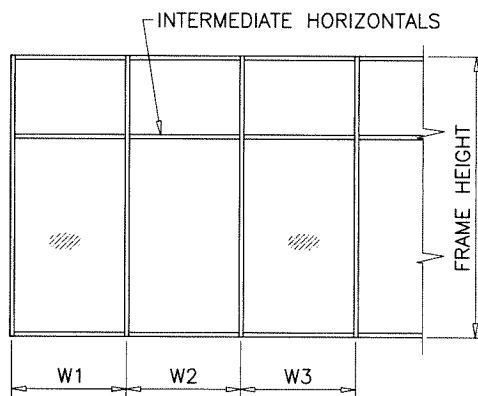

WIDTH (W) = W1  
AT FRAME JAMB

WIDTH (W) =  $\frac{W2 + W3}{2}$   
AT FRAME MULLION

JAMB & MULLIONS  
(LEVEL 'D' IMPACT)  
WITH HORIZONTALS

Sealed: 8/19/2025

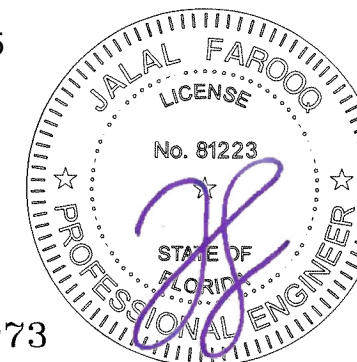

FL #19973

afc

AL-FAROOQ CORPORATION  
ENGINEERS & PRODUCT DEVELOPMENT  
9360 SUNSET DRIVE, SUITE 220  
MIAMI, FLORIDA 33173 (C.A.N. 3538)  
TEL. (305) 264-8100 FAX. (305) 262-6978

SERIES FRONT SET ALUM WINDOW WALL SYS. (L.M.I.)

Aldora Aluminum & Glass Products Inc.  
4250 Coral Ridge Drive, Suite 101  
Coral Springs, FL 33065  
Tel. (954) 784-6900 Fax. (954) 784-6901

revisions:  
no. date by description

date: 06-10-21

scale: -

dr. by: TARIQ

chk. by:

drawing no.

21-51F

sheet 10 of 27

COMP-ANL\21-51FAGP

DESIGN LOAD CAPACITY - PSF  
NON-THERMAL MULLION  
WITH OR WITHOUT HORIZONTALS

NOMINAL DIMS.		MULLION 'M5'	
WIDTH (W)	FRAME HEIGHT	EXT.(+)	INT.(-)
30"	84"	65.0	65.0
36"		65.0	65.0
42"		65.0	65.0
48"		65.0	65.0
54"		65.0	65.0
60"		65.0	65.0
66"		65.0	65.0
30"	90"	65.0	65.0
36"		65.0	65.0
42"		65.0	65.0
48"		65.0	65.0
54"		65.0	65.0
60"		65.0	65.0
30"	96"	65.0	65.0
36"		65.0	65.0
42"		65.0	65.0
48"		65.0	65.0
54"		65.0	65.0
60"		65.0	65.0
30"	102"	65.0	65.0
36"		65.0	65.0
42"		65.0	65.0
48"		65.0	65.0
54"		65.0	65.0
30"	108"	65.0	65.0
36"		65.0	65.0
42"		65.0	65.0
48"		65.0	65.0
30"	114"	65.0	65.0
36"		65.0	65.0
42"		65.0	65.0
48"		65.0	65.0
30"	120"	65.0	65.0
36"		65.0	65.0
42"		65.0	65.0
48"		65.0	65.0

INTERPOLATION BETWEEN WIDTHS OR HEIGHTS ALLOWED.

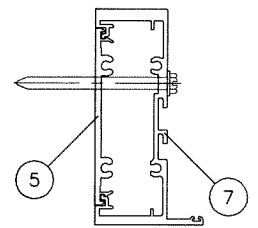

USE ANCHOR SPACING SHOWN ON SHEET 1.

ANCHORED JAMBS ONLY.

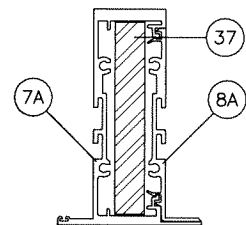

MULLION 'M5'  
(LEVEL 'D' IMPACT)

	Ix IN <sup>4</sup>	Sx IN <sup>3</sup>
ALUMINUM	5.670	2.514
STEEL	3.3333	1.6667
TOTAL Ix ALUM + Ix STL X 2.9	15.2409	

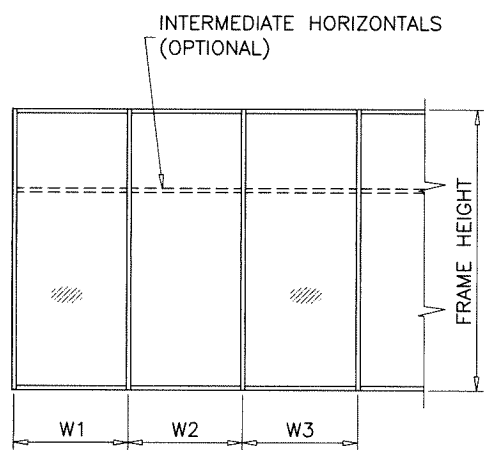

WIDTH (W) = W1  
AT FRAME JAMB

WIDTH (W) =  $\frac{W2 + W3}{2}$   
AT FRAME MULLION

MULLION  
(LEVEL 'D' IMPACT)  
WITH OR WITHOUT HORIZONTALS

Sealed: 8/19/2025



FL #19973

**AL-FAROOQ CORPORATION**  
ENGINEERS & PRODUCT DEVELOPMENT  
9360 SUNSET DRIVE, SUITE 220  
MIAMI, FLORIDA 33173 (C.A.N. 353B)  
TEL. (305) 264-8100 FAX. (305) 262-6978  
COMP-ANL\21-51FAGP

SERIES FRONT SET ALUM WINDOW WALL SYS. (L.M.I.)  
**Aldora Aluminum & Glass Products Inc.**  
4250 Coral Ridge Drive, Suite 101  
Coral Springs, FL. 33065  
Tel. (954) 784-6900 Fax. (954) 784-6901

no.	date	by	description

date: 06-10-21  
scale: -  
dr. by: TARIQ  
chk. by:

drawing no.  
**21-51F**  
sheet 11 of 27

DESIGN LOAD CAPACITY - PSF NON-THERMAL MULLION WITH INTERMEDIATE HORIZONTALS			
NOMINAL DIMS.		JAMB 'J5' MULLION 'M1'	
WIDTH (W)	FRAME HEIGHT	EXT.(+)	INT.(-)
30"	84"	90.0	90.0
36"		90.0	90.0
42"		90.0	90.0
48"		90.0	90.0
53-1/2"		90.0	90.0
30"	90"	90.0	90.0
36"		90.0	90.0
42"		90.0	90.0
48"		90.0	90.0
53-1/2"		81.2	81.2

INTERPOLATION BETWEEN WIDTHS OR HEIGHTS ALLOWED.

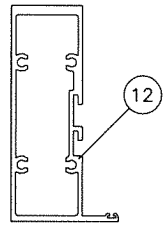

JAMB 'J5'  
(LEVEL 'D' & 'E' IMPACT)

Ix IN <sup>4</sup>	Sx IN <sup>3</sup>
4.027	1.788

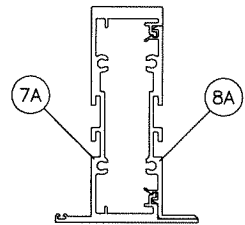

MULLION 'M1'  
(LEVEL 'D' & 'E' IMPACT)

Ix IN <sup>4</sup>	Sx IN <sup>3</sup>
5.670	2.514

NOTE:  
JAMB 'J5' MAY BE SECURED (ANCHORED)  
OR UNSECURED (UNANCHORED)  
FOR SECURED JAMBS, USE ANCHOR SPACING  
SHOWN ON SHEET 1.  
FOR UNSECURED JAMBS VERIFY MAX. GAPS ON  
SHEETS 21 OR 23.

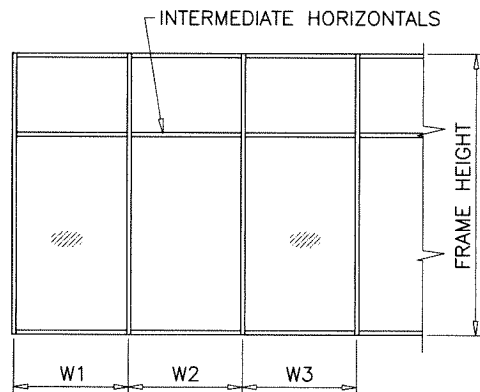

WIDTH (W) = W1  
AT FRAME JAMB

$$\text{WIDTH (W) AT FRAME MULLION} = \frac{W2 + W3}{2}$$

DESIGN LOAD CAPACITY - PSF NON-THERMAL MULLION WITH INTERMEDIATE HORIZONTALS			
NOMINAL DIMS.		JAMB 'J2'/'J2A' MULLION 'M2'	
WIDTH (W)	FRAME HEIGHT	EXT.(+)	INT.(-)
30"	84"	120.0	135.0
36"		120.0	135.0
42"		120.0	135.0
48"		120.0	135.0
54"		120.0	135.0
60"		120.0	135.0
66"		100.0	100.0
72"		100.0	100.0
30"	90"	120.0	135.0
36"		120.0	135.0
42"		120.0	135.0
48"		120.0	135.0
54"		120.0	135.0
56"		120.0	135.0
60"		100.0	100.0
66"		100.0	100.0
72"	100.0	100.0	
30"	96"	120.0	135.0
36"		120.0	135.0
42"		120.0	135.0
48"		120.0	135.0
52"		120.0	135.0
54"		100.0	100.0
60"		100.0	100.0
66"		100.0	100.0
72"	100.0	100.0	
30"	102"	120.0	135.0
39"		120.0	135.0
42"		120.0	135.0
48"		120.0	135.0
49"		120.0	135.0
54"		100.0	100.0
60"		100.0	100.0
66"		100.0	100.0
72"	98.6	98.6	
30"	108"	120.0	135.0
36"		120.0	135.0
42"		120.0	135.0
46"		120.0	135.0
48"		100.0	100.0
54"		100.0	100.0
60"		100.0	100.0
66"		96.0	96.0
72"	88.0	88.0	
30"	114"	120.0	135.0
36"		120.0	135.0
42"		120.0	135.0
44"		120.0	130.0
48"		100.0	100.0
54"		100.0	100.0
60"		94.7	94.7
66"		86.1	86.1
72"	79.0	79.0	

DESIGN LOAD CAPACITY - PSF NON-THERMAL MULLION WITH INTERMEDIATE HORIZONTALS			
NOMINAL DIMS.		JAMB 'J2'/'J2A' MULLION 'M2'	
WIDTH (W)	FRAME HEIGHT	EXT.(+)	INT.(-)
30"	120"	120.0	135.0
36"		120.0	135.0
42"		120.0	122.9
48"		100.0	100.0
54"		95.0	95.0
60"		85.5	85.5
66"		77.7	77.7
72"		71.3	71.3
30"	126"	100.0	100.0
36"		100.0	100.0
42"		100.0	100.0
48"		97.0	97.0
54"		86.2	86.2
60"		77.6	77.6
66"		70.5	70.5
68"		68.4	68.4
30"	132"	100.0	100.0
36"		100.0	100.0
42"		100.0	100.0
48"		88.3	88.3
54"		78.5	78.5
60"		70.7	70.7
65"		65.2	65.2
72"		62.6	62.6
30"	138"	100.0	100.0
36"		100.0	100.0
42"		92.4	92.4
48"		80.8	80.8
54"		71.8	71.8
60"		64.7	64.7
62"		62.6	62.6
72"		59.1	59.1
30"	144"	100.0	100.0
36"		98.4	98.4
42"		84.4	84.4
48"		73.8	73.8
54"		65.6	65.6
60"		59.1	59.1
72"		59.1	59.1

INTERPOLATION BETWEEN WIDTHS OR HEIGHTS ALLOWED.

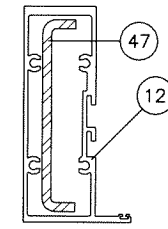

JAMB 'J2'  
(LEVEL 'D' & 'E' IMPACT)

	Ix IN <sup>4</sup>	Sx IN <sup>3</sup>
ALUMINUM	4.027	1.788
STEEL	1.566	.783
TOTAL Ix ALUM + Ix STL X 2.9	8.523	

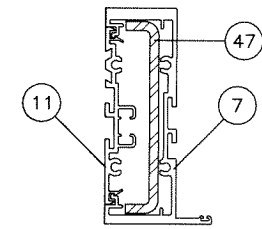

JAMB 'J2A'  
(LEVEL 'D' & 'E' IMPACT)

	Ix IN <sup>4</sup>	Sx IN <sup>3</sup>
ALUMINUM	5.684	2.521
STEEL	1.566	.783
TOTAL Ix ALUM + Ix STL X 2.9	10.180	

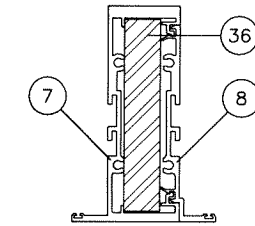
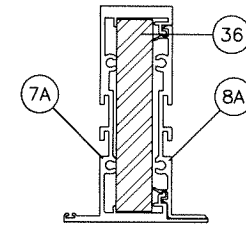

MULLION 'M2'  
(LEVEL 'D' & 'E' IMPACT)

	Ix IN <sup>4</sup>	Sx IN <sup>3</sup>
ALUMINUM	5.670	2.514
STEEL	4.000	2.000
TOTAL Ix ALUM + Ix STL X 2.9	17.270	

NOTE:  
JAMBS 'J2' AND 'J2A' MAY BE SECURED (ANCHORED)  
OR UNSECURED (UNANCHORED)  
FOR SECURED JAMBS, USE ANCHOR SPACING  
SHOWN ON SHEET 1.  
FOR UNSECURED JAMBS VERIFY MAX. GAPS ON  
SHEETS 21 OR 23.

JAMB & MULLIONS  
(LEVEL 'D' & 'E' IMPACT)  
WITH HORIZONTALS

Sealed: 8/19/2025

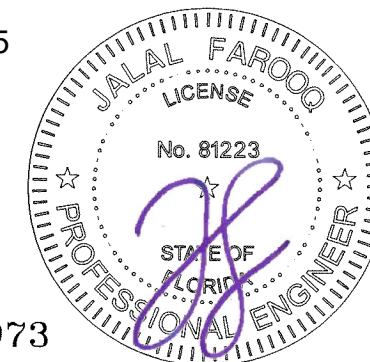

FL #19973

**AL-FAROOQ CORPORATION**  
ENGINEERS & PRODUCT DEVELOPMENT  
9360 SUNSET DRIVE, SUITE 220  
MIAMI, FLORIDA 33173  
TEL. (305) 262-6978  
FAX. (305) 262-6978  
COMP-ANL\21-51FAGP

SERIES FRONT SET ALUM WINDOW WALL SYS. (L.M.I.)  
**Aldora Aluminum & Glass Products Inc.**  
4250 Coral Ridge Drive, Suite 101  
Coral Springs, FL 33065  
Tel. (954) 784-6900 Fax. (954) 784-6901

revisions:	no	date	by	description
date:	06-10-21	scale:	-	dr. by: TARIQ
chk. by:				
drawing no.	21-51F			
sheet	11.1 of 27			

WOOD BUCKS AND METAL STRUCTURE NOT BY 'ALDORA'  
MUST SUSTAIN LOADS IMPOSED BY GLAZING SYSTEM  
AND TRANSFER THEM TO THE BUILDING STRUCTURE.

**TYPICAL ANCHORS:** SEE ELEV. FOR SPACING

**TYPE 'AW'** - 1/4" DIA. ULTRACON+ BY 'DEWALT' (Fu=164 KSI, Fy=148 KSI)  
INTO 2BY WOOD BUCKS OR WOOD STRUCTURES  
WITH 1-1/2" MIN. PENETRATION INTO WOOD  
THRU 1BY WOOD BUCKS INTO CONCRETE OR BLOCKS  
WITH 1-1/2" MIN. EMBED INTO CONCRETE (HEAD/SILL/JAMBS)  
WITH 1-1/4" MIN. EMBED INTO BLOCKS (JAMBS)

**TYPE 'AC'** - 1/4" DIA. ULTRACON+ BY 'DEWALT' (Fu=164 KSI, Fy=148 KSI)  
DIRECTLY INTO CONCRETE OR BLOCKS  
WITH 1-3/4" MIN. EMBED INTO CONCRETE (HEAD/SILL/JAMBS)  
WITH 1-3/4" MIN. EMBED INTO GROUT FILLED BLOCKS (JAMBS)

**ANCHOR EDGE DISTANCES**

INTO CONCRETE AND BLOCKS = 2-1/2" MIN.  
INTO WOOD STRUCTURE = 1" MIN.

**TYPE 'BW'** - 5/16" DIA ULTRACON BY 'DEWALT' (Fu=177 KSI, Fy=155 KSI)  
INTO 2BY WOOD BUCKS OR WOOD STRUCTURES  
WITH 1-1/2" MIN. PENETRATION INTO WOOD  
THRU 1BY WOOD BUCKS INTO CONCRETE OR BLOCKS  
WITH 1-1/2" MIN. EMBED INTO CONCRETE (HEAD/SILL/JAMBS)  
WITH 1-1/4" MIN. EMBED INTO BLOCKS (JAMBS)

**TYPE 'BC'** - 5/16" DIA ULTRACON BY 'DEWALT' (Fu=177 KSI, Fy=155 KSI)  
DIRECTLY INTO CONCRETE OR BLOCKS  
WITH 1-3/4" MIN. EMBED INTO CONCRETE (HEAD/SILL/JAMBS)  
WITH 1-3/4" MIN. EMBED INTO GROUT FILLED BLOCKS (JAMBS)

**ANCHOR EDGE DISTANCES**

INTO CONCRETE AND BLOCKS = 3-1/8" MIN.  
INTO WOOD STRUCTURE = 1-1/2" MIN.

**TYPE 'CM'** - #14 SELF DRILLING SCREWS ST/ST (GRADE 5 CRS)  
INTO F.B.C. APPROVED MULLIONS  
OR  
INTO METAL STRUCTURES (HEAD/SILL/JAMBS)  
(3) THREADS MIN. PENETRATION BEYOND SUBSTRATE  
ALUMINUM: 1/8" THK. MIN. (6063-T5 MIN.)  
STEEL: 1/8" THK. MIN. (Fy = 36 KSI MIN.)  
(STEEL IN CONTACT WITH ALUMINUM TO BE PLATED OR PAINTED)

**ANCHOR EDGE DISTANCES**

INTO METAL STRUCTURE = 1/2" MIN.

WOOD AT HEAD, SILL OR JAMBS SG = 0.55 MIN.  
CONCRETE AT HEAD, SILL OR JAMBS f'c = 3000 PSI MIN.  
C-90 HOLLOW/FILLED BLOCK AT JAMBS f'm = 2000 PSI MIN.

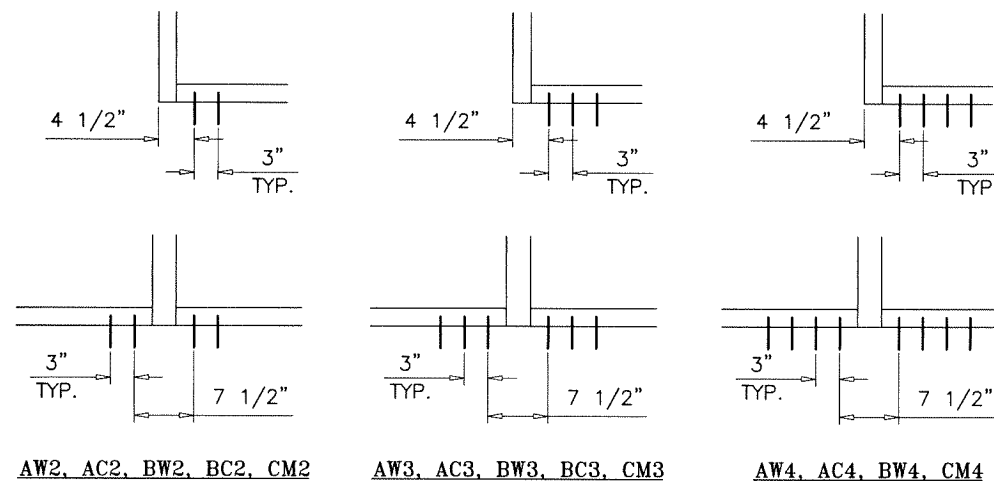

**ANCHORS TYPES:**

- AW2 = (2) ANCHORS TYPE 'AW' AT EACH SIDE OF JAMB AND MULLION
- AC2 = (2) ANCHORS TYPE 'AC' AT EACH SIDE OF JAMB AND MULLION
- BW2 = (2) ANCHORS TYPE 'BW' AT EACH SIDE OF JAMB AND MULLION
- BC2 = (2) ANCHORS TYPE 'BC' AT EACH SIDE OF JAMB AND MULLION
- CM2 = (2) ANCHORS TYPE 'CM' AT EACH SIDE OF JAMB AND MULLION
  
- AW3 = (3) ANCHORS TYPE 'AW' AT EACH SIDE OF JAMB AND MULLION
- AC3 = (3) ANCHORS TYPE 'AC' AT EACH SIDE OF JAMB AND MULLION
- BW3 = (3) ANCHORS TYPE 'BW' AT EACH SIDE OF JAMB AND MULLION
- BC3 = (3) ANCHORS TYPE 'BC' AT EACH SIDE OF JAMB AND MULLION
- CM3 = (3) ANCHORS TYPE 'CM' AT EACH SIDE OF JAMB AND MULLION
  
- AW4 = (4) ANCHORS TYPE 'AW' AT EACH SIDE OF JAMB AND MULLION
- AC4 = (4) ANCHORS TYPE 'AC' AT EACH SIDE OF JAMB AND MULLION
- BW4 = (4) ANCHORS TYPE 'BW' AT EACH SIDE OF JAMB AND MULLION
- CM4 = (4) ANCHORS TYPE 'CM' AT EACH SIDE OF JAMB AND MULLION

Sealed: 8/19/2025

SEE SHEETS 12 & 16 FOR ANCHOR CAPACITIES.

ANCHORS

FL #19973

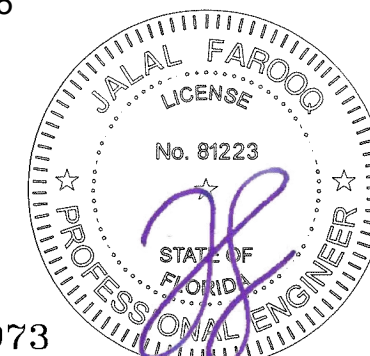

**AL-FAROOQ CORPORATION**  
ENGINEERS & PRODUCT DEVELOPMENT  
9360 SUNSET DRIVE, SUITE 220  
MIAMI, FLORIDA 33173  
TEL. (305) 264-8100 FAX. (305) 262-6978  
(C.A.N. 3538)

SERIES FRONT SET ALUM WINDOW WALL SYS. (L.M.I.)  
**Aldora Aluminum & Glass Products Inc.**  
4250 Coral Ridge Drive, Suite 101  
Coral Springs, FL. 33065  
Tel. (954) 784-6900 Fax. (954) 784-6901

revisions:	no.	date	by	description
date:	06-10-21	scale:	-	dr. by: TARIQ
				chk. by:
drawing no.				
21-51F				
sheet 12 of 27				

COMP-ANL\21-51FACP

ANCHOR LOAD CAPACITY - PSF (1/4" MAX. SHIMS)																
EXT.(+) & INT.(-)																
NOMINAL DIMS.		ANCHORS TYPE 'AW'			ANCHORS TYPE 'BW'			ANCHORS TYPE 'AC'			ANCHORS TYPE 'BC'			ANCHORS TYPE 'CM'		
WIDTH (W)	FRAME HEIGHT	AW2	AW3	AW4	BW2	BW3	BW4	AC2	AC3	AC4	BC2	BC3	BC4	CM2	CM3	CM4
30"	96"	123.3	135.0	135.0	135.0	135.0	135.0	135.0	135.0	135.0	135.0	135.0	135.0	135.0	135.0	135.0
36"		106.7	135.0	135.0	135.0	135.0	135.0	135.0	135.0	135.0	135.0	135.0	135.0	135.0	135.0	135.0
42"		95.1	135.0	135.0	125.1	135.0	135.0	124.3	135.0	135.0	135.0	135.0	135.0	135.0	135.0	135.0
48"		86.7	130.0	135.0	114.0	135.0	135.0	113.3	135.0	135.0	135.0	135.0	135.0	127.7	135.0	135.0
52"		82.3	123.4	135.0	108.2	135.0	135.0	107.6	135.0	135.0	134.2	135.0	135.0	121.2	135.0	135.0
54"		80.4	120.6	135.0	105.7	135.0	135.0	105.1	135.0	135.0	131.1	135.0	135.0	118.4	135.0	135.0
60"		75.6	113.5	135.0	99.5	135.0	135.0	98.9	135.0	135.0	123.3	135.0	135.0	111.4	135.0	135.0
66"		72.0	108.1	135.0	94.8	135.0	135.0	94.2	135.0	135.0	117.5	135.0	135.0	106.1	135.0	135.0
72"	69.3	104.0	135.0	91.2	135.0	135.0	90.7	135.0	135.0	113.1	135.0	135.0	102.1	135.0	135.0	
30"	102"	114.8	135.0	135.0	135.0	135.0	135.0	135.0	135.0	135.0	135.0	135.0	135.0	135.0	135.0	135.0
36"		99.0	135.0	135.0	130.3	135.0	135.0	129.5	135.0	135.0	135.0	135.0	135.0	135.0	135.0	135.0
42"		88.0	132.1	135.0	115.8	135.0	135.0	115.1	135.0	135.0	135.0	135.0	135.0	129.7	135.0	135.0
48"		80.0	120.0	135.0	105.2	135.0	135.0	104.6	135.0	135.0	130.5	135.0	135.0	117.8	135.0	135.0
52"		75.8	113.7	135.0	99.7	135.0	135.0	99.1	135.0	135.0	123.6	135.0	135.0	111.6	135.0	135.0
54"		74.0	110.9	135.0	97.3	135.0	135.0	96.7	135.0	135.0	120.6	135.0	135.0	108.9	135.0	135.0
60"		69.3	104.0	135.0	91.2	135.0	135.0	90.7	135.0	135.0	113.1	135.0	135.0	102.1	135.0	135.0
66"		65.8	98.7	131.5	86.5	129.8	135.0	86.0	129.0	135.0	107.3	135.0	135.0	96.9	135.0	135.0
72"	63.0	94.5	126.1	82.9	124.4	135.0	82.4	123.6	135.0	102.8	135.0	135.0	92.8	135.0	135.0	
30"	108"	107.4	135.0	135.0	135.0	135.0	135.0	135.0	135.0	135.0	135.0	135.0	135.0	135.0	135.0	135.0
36"		92.4	135.0	135.0	121.6	135.0	135.0	120.9	135.0	135.0	135.0	135.0	135.0	135.0	135.0	135.0
42"		82.0	123.0	135.0	107.8	135.0	135.0	107.2	135.0	135.0	133.7	135.0	135.0	120.7	135.0	135.0
48"		74.3	111.4	135.0	97.7	135.0	135.0	97.1	135.0	135.0	121.1	135.0	135.0	109.4	135.0	135.0
52"		70.2	105.4	135.0	92.4	135.0	135.0	91.9	135.0	135.0	114.6	135.0	135.0	103.5	135.0	135.0
54"		68.5	102.7	135.0	90.1	135.0	135.0	89.5	134.3	135.0	111.7	135.0	135.0	100.9	135.0	135.0
60"		64.0	96.0	128.0	84.2	126.3	135.0	83.7	125.5	135.0	104.4	135.0	135.0	94.3	135.0	135.0
66"		60.5	90.8	121.0	79.6	119.4	135.0	79.1	118.7	135.0	98.7	135.0	135.0	89.1	133.7	135.0
72"	57.8	86.7	115.6	76.0	114.0	135.0	75.6	113.3	135.0	94.2	135.0	135.0	85.1	127.7	135.0	
30"	114"	100.8	135.0	135.0	132.7	135.0	135.0	131.9	135.0	135.0	135.0	135.0	135.0	135.0	135.0	135.0
36"		86.7	130.0	135.0	114.0	135.0	135.0	113.3	135.0	135.0	135.0	135.0	135.0	127.7	135.0	135.0
42"		76.7	115.0	135.0	100.9	135.0	135.0	100.3	135.0	135.0	125.1	135.0	135.0	113.0	135.0	135.0
48"		69.3	104.0	135.0	91.2	135.0	135.0	90.7	135.0	135.0	113.1	135.0	135.0	102.1	135.0	135.0
52"		65.5	98.2	130.9	86.1	129.1	135.0	85.6	128.4	135.0	106.7	135.0	135.0	96.4	135.0	135.0
54"		63.8	95.6	127.5	83.9	125.8	135.0	83.4	125.1	135.0	104.0	135.0	135.0	93.9	135.0	135.0
60"		59.4	89.1	118.9	78.2	117.3	135.0	77.7	116.6	135.0	96.9	135.0	135.0	87.5	131.3	135.0
66"		56.0	84.0	112.1	73.7	110.5	135.0	73.3	109.9	135.0	91.4	135.0	135.0	82.5	123.8	135.0
72"	53.3	80.0	106.7	70.2	105.2	135.0	69.7	104.6	135.0	87.0	130.5	135.0	78.6	117.8	135.0	
30"	120"	95.1	135.0	135.0	125.1	135.0	135.0	124.3	135.0	135.0	135.0	135.0	135.0	135.0	135.0	135.0
36"		81.6	122.4	135.0	107.3	135.0	135.0	106.7	135.0	135.0	133.0	135.0	135.0	120.2	135.0	135.0
42"		72.0	108.1	135.0	94.8	135.0	135.0	94.2	135.0	135.0	117.5	135.0	135.0	106.1	135.0	135.0
48"		65.0	97.5	130.0	85.5	128.3	135.0	85.0	127.5	135.0	106.0	135.0	135.0	95.8	135.0	135.0
52"		61.3	91.9	122.6	80.6	120.9	135.0	80.1	120.2	135.0	99.9	135.0	135.0	90.3	135.0	135.0
54"		59.6	89.5	119.3	78.5	117.7	135.0	78.0	117.0	135.0	97.3	135.0	135.0	87.9	131.8	135.0
60"		55.5	83.2	110.9	73.0	109.4	135.0	72.5	108.8	135.0	90.5	135.0	135.0	81.7	122.6	135.0
66"		52.2	78.2	104.3	68.6	102.9	135.0	68.2	102.3	135.0	85.1	127.6	135.0	76.8	115.3	135.0
72"	49.5	74.3	99.0	65.1	97.7	130.3	64.8	97.1	129.5	80.8	121.1	135.0	73.0	109.4	135.0	
30"	126"	89.9	134.9	135.0	118.3	135.0	135.0	117.6	135.0	135.0	135.0	135.0	135.0	132.5	135.0	135.0
36"		77.0	115.6	135.0	101.3	135.0	135.0	100.7	135.0	135.0	125.6	135.0	135.0	113.5	135.0	135.0
42"		67.9	101.9	135.0	89.3	134.0	135.0	88.8	133.2	135.0	110.8	135.0	135.0	100.0	135.0	135.0
48"		61.2	91.8	122.4	80.5	120.7	135.0	80.0	120.0	135.0	99.8	135.0	135.0	90.1	135.0	135.0
52"		57.6	86.4	115.2	75.8	113.6	135.0	75.3	113.0	135.0	93.9	135.0	135.0	84.8	127.3	135.0
54"		56.0	84.0	112.1	73.7	110.5	135.0	73.3	109.9	135.0	91.4	135.0	135.0	82.5	123.8	135.0
60"		52.0	78.0	104.0	68.4	102.6	135.0	68.0	102.0	135.0	84.8	127.2	135.0	76.6	114.9	135.0
66"		48.8	73.2	97.6	64.2	96.3	128.4	63.8	95.7	127.6	79.6	119.4	135.0	71.9	107.8	135.0

ANCHOR LOAD CAPACITY - PSF (1/4" MAX. SHIMS)																
EXT.(+) & INT.(-)																
NOMINAL DIMS.		ANCHORS TYPE 'AW'			ANCHORS TYPE 'BW'			ANCHORS TYPE 'AC'			ANCHORS TYPE 'BC'			ANCHORS TYPE 'CM'		
WIDTH (W)	FRAME HEIGHT	AW2	AW3	AW4	BW2	BW3	BW4	AC2	AC3	AC4	BC2	BC3	BC4	CM2	CM3	CM4
30"	132"	85.3	128.0	135.0	112.2	135.0	135.0	111.6	135.0	135.0	135.0	135.0	135.0	125.7	135.0	135.0
36"		73.0	109.5	135.0	96.0	135.0	135.0	95.4	135.0	135.0	119.0	135.0	135.0	107.5	135.0	135.0
42"		64.2	96.4	128.5	84.5	126.8	135.0	84.0	126.0	135.0	104.8	135.0	135.0	94.6	135.0	135.0
48"		57.8	86.7	115.6	76.0	114.0	135.0	75.6	113.3	135.0	94.2	135.0	135.0	85.1	127.7	135.0
52"		54.3	81.5	108.7	71.5	107.2	135.0	71.1	106.6	135.0	88.6	132.9	135.0	80.0	120.1	135.0
54"		52.8	79.2	105.7	69.5	104.2	135.0	69.1	103.6	135.0	86.1	129.2	135.0	77.8	116.7	135.0
60"	48.9	73.4	97.9	64.4	96.6	128.8	64.0	96.0	128.0	79.8	119.7	135.0	72.1	108.1	135.0	
30"	138"	81.2	121.8	135.0	106.8	135.0	135.0	106.1	135.0	135.0	132.4	135.0	135.0	119.6	135.0	135.0
36"		69.3	104.0	135.0	91.2	135.0	135.0	90.7	135.0	135.0	113.1	135.0	135.0	102.1	135.0	135.0
42"		61.0	91.4	121.9	80.2	120.3	135.0	79.7	119.6	135.0	99.4	135.0	135.0	89.8	134.7	135.0
48"		54.7	82.1	109.5	72.0	108.0	135.0	71.6	107.4	135.0	89.3	133.9	135.0	80.6	120.9	135.0
52"		51.4	77.1	102.9	67.6	101.5	135.0	67.3	100.9	134.5	83.9	125.8	135.0	75.8	113.6	135.0
54"		50.0	75.0	99.9	65.7	98.6	131.5	65.3	98.0	130.7	81.5	122.2	135.0	73.6	110.4	135.0
60"	46.2	69.3	92.4	60.8	91.2	121.6	60.4	90.7	120.9	75.4	113.1	135.0	68.1	102.1	135.0	
30"	144"	77.4	116.1	135.0	101.8	135.0	135.0	101.2	135.0	135.0	126.2	135.0	135.0	114.0	135.0	135.0
36"		66.0	99.0	132.1	86.9	130.3	135.0	86.3	129.5	135.0	107.7	135.0	135.0	97.3	135.0	135.0
42"		58.0	87.0	116.0	76.3	114.4	135.0	75.8	113.7	135.0	94.6	135.0	135.0	85.4	128.1	135.0
48"		52.0	78.0	104.0	68.4	102.6	135.0	68.0	102.0	135.0	84.8	127.2	135.0	76.6	114.9	135.0
52"		48.8	73.2	97.6	64.2	96.3	128.4	63.8	95.7	127.7	79.6	119.4	135.0	71.9	107.9	135.0
54"		47.4	71.1	94.8	62.4	93.5	124.7	62.0	93.0	124.0	77.3	116.0	135.0	69.8	104.8	135.0
60"	43.8	65.7	87.6	57.6	86.4	115.										

ANCHOR LOAD CAPACITY - PSF (3/8" MAX. SHIMS) EXT.(+) & INT.(-)										
NOMINAL DIMS.		ANCHORS TYPE 'BW'			ANCHORS TYPE 'BC'			ANCHORS TYPE 'CM'		
WIDTH (W)	FRAME HEIGHT	BW2	BW3	BW4	BC2	BC3	BC4	CM2	CM3	CM4
30"	96"	123.7	135.0	135.0	123.7	135.0	135.0	88.3	132.5	135.0
36"		107.1	135.0	135.0	107.1	135.0	135.0	76.4	114.7	135.0
42"		95.5	135.0	135.0	95.5	135.0	135.0	68.1	102.2	135.0
48"		87.0	130.5	135.0	87.0	130.5	135.0	62.1	93.2	124.2
52"		82.6	123.9	135.0	82.6	123.9	135.0	58.9	88.5	117.9
54"		80.7	121.0	135.0	80.7	121.0	135.0	57.6	86.4	115.2
60"		75.9	113.9	135.0	75.9	113.9	135.0	54.2	81.3	108.4
66"		72.3	108.5	135.0	72.3	108.5	135.0	51.6	77.4	103.2
72"	69.6	104.4	135.0	69.6	104.4	135.0	49.7	74.5	99.3	
30"	102"	115.2	135.0	135.0	115.2	135.0	135.0	82.2	123.4	135.0
36"		99.4	135.0	135.0	99.4	135.0	135.0	71.0	106.5	135.0
42"		88.4	132.6	135.0	88.4	132.6	135.0	63.1	94.6	126.1
48"		80.3	120.5	135.0	80.3	120.5	135.0	57.3	86.0	114.6
52"		76.1	114.1	135.0	76.1	114.1	135.0	54.3	81.5	108.6
54"		74.2	111.4	135.0	74.2	111.4	135.0	53.0	79.5	106.0
60"		69.6	104.4	135.0	69.6	104.4	135.0	49.7	74.5	99.3
66"		66.0	99.0	132.0	66.0	99.0	132.0	47.1	70.7	94.2
72"	63.3	94.9	126.5	63.3	94.9	126.5	45.2	67.8	90.3	
30"	108"	107.8	135.0	135.0	107.8	135.0	135.0	76.9	115.4	135.0
36"		92.8	135.0	135.0	92.8	135.0	135.0	66.2	99.4	132.4
42"		82.3	123.4	135.0	82.3	123.4	135.0	58.7	88.1	117.4
48"		74.6	111.9	135.0	74.6	111.9	135.0	53.2	79.9	106.4
52"		70.5	105.8	135.0	70.5	105.8	135.0	50.3	75.5	100.6
54"		68.7	103.1	135.0	68.7	103.1	135.0	49.1	73.6	98.1
60"		64.2	96.4	128.5	64.2	96.4	128.5	45.8	68.8	91.7
66"		60.7	91.1	121.5	60.7	91.1	121.5	43.3	65.0	86.7
72"	58.0	87.0	116.0	58.0	87.0	116.0	41.4	62.1	82.8	
30"	114"	101.2	135.0	135.0	101.2	135.0	135.0	72.2	108.4	135.0
36"		87.0	130.5	135.0	87.0	130.5	135.0	62.1	93.2	124.2
42"		77.0	115.5	135.0	77.0	115.5	135.0	54.9	82.4	109.9
48"		69.6	104.4	135.0	69.6	104.4	135.0	49.7	74.5	99.3
52"		65.7	98.6	131.4	65.7	98.6	131.4	46.9	70.4	93.8
54"		64.0	96.0	128.0	64.0	96.0	128.0	45.7	68.5	91.3
60"		59.7	89.5	119.3	59.7	89.5	119.3	42.6	63.9	85.1
66"		56.2	84.4	112.5	56.2	84.4	112.5	40.1	60.2	80.3
72"	53.5	80.3	107.1	53.5	80.3	107.1	38.2	57.3	76.4	
30"	120"	95.5	135.0	135.0	95.5	135.0	135.0	68.1	102.2	135.0
36"		81.9	122.8	135.0	81.9	122.8	135.0	58.4	87.7	116.9
42"		72.3	108.5	135.0	72.3	108.5	135.0	51.6	77.4	103.2
48"		65.3	97.9	130.5	65.3	97.9	130.5	46.6	69.9	93.1
52"		61.5	92.3	123.0	61.5	92.3	123.0	43.9	65.9	87.8
54"		59.9	89.8	119.7	59.9	89.8	119.7	42.7	64.1	85.4
60"		55.7	83.5	111.4	55.7	83.5	111.4	39.7	59.6	79.5
66"		52.4	78.5	104.7	52.4	78.5	104.7	37.4	56.1	74.7
72"	49.7	74.6	99.4	49.7	74.6	99.4	35.5	53.2	71.0	
30"	126"	90.3	135.0	135.0	90.3	135.0	135.0	64.4	96.7	128.9
36"		77.3	116.0	135.0	77.3	116.0	135.0	55.2	82.8	110.4
42"		68.2	102.3	135.0	68.2	102.3	135.0	48.7	73.0	97.3
48"		61.4	92.1	122.8	61.4	92.1	122.8	43.8	65.8	87.6
52"		57.8	86.7	115.6	57.8	86.7	115.6	41.3	61.9	82.5
54"		56.2	84.4	112.5	56.2	84.4	112.5	40.1	60.2	80.3
60"		52.2	78.3	104.4	52.2	78.3	104.4	37.3	55.9	74.5
66"		49.0	73.5	98.0	49.0	73.5	98.0	35.0	52.5	69.9

ANCHOR LOAD CAPACITY - PSF (3/8" MAX. SHIMS) EXT.(+) & INT.(-)										
NOMINAL DIMS.		ANCHORS TYPE 'BW'			ANCHORS TYPE 'BC'			ANCHORS TYPE 'CM'		
WIDTH (W)	FRAME HEIGHT	BW2	BW3	BW4	BC2	BC3	BC4	CM2	CM3	CM4
30"	132"	85.7	128.5	135.0	85.7	128.5	135.0	61.1	91.7	122.3
36"		73.3	109.9	135.0	73.3	109.9	135.0	52.3	78.5	104.6
42"		64.5	96.7	129.0	64.5	96.7	129.0	46.0	69.1	92.0
48"		58.0	87.0	116.0	58.0	87.0	116.0	41.4	62.1	82.8
52"		54.5	81.8	109.1	54.5	81.8	109.1	38.9	58.4	77.9
54"		53.0	79.5	106.1	53.0	79.5	106.1	37.8	56.8	75.7
60"	49.1	73.7	98.3	49.1	73.7	98.3	35.1	52.6	70.1	
30"	138"	81.5	122.2	135.0	81.5	122.2	135.0	58.1	87.3	116.3
36"		69.6	104.4	135.0	69.6	104.4	135.0	49.7	74.5	99.3
42"		61.2	91.8	122.4	61.2	91.8	122.4	43.7	65.5	87.3
48"		54.9	82.4	109.9	54.9	82.4	109.9	39.2	58.8	78.4
52"		51.6	77.4	103.3	51.6	77.4	103.3	36.8	55.3	73.7
54"		50.2	75.2	100.3	50.2	75.2	100.3	35.8	53.7	71.6
60"	46.4	69.6	92.8	46.4	69.6	92.8	33.1	49.7	66.2	
30"	144"	77.7	116.5	135.0	77.7	116.5	135.0	55.4	83.2	110.9
36"		66.3	99.4	132.6	66.3	99.4	132.6	47.3	71.0	94.6
42"		58.2	87.3	116.4	58.2	87.3	116.4	41.5	62.3	83.1
48"		52.2	78.3	104.4	52.2	78.3	104.4	37.3	55.9	74.5
52"		49.0	73.5	98.0	49.0	73.5	98.0	35.0	52.5	69.9
54"		47.6	71.4	95.2	47.6	71.4	95.2	34.0	51.0	67.9
60"	44.0	65.9	87.9	44.0	65.9	87.9	31.4	47.1	62.7	

INTERPOLATION BETWEEN WIDTHS OR HEIGHTS ALLOWED.

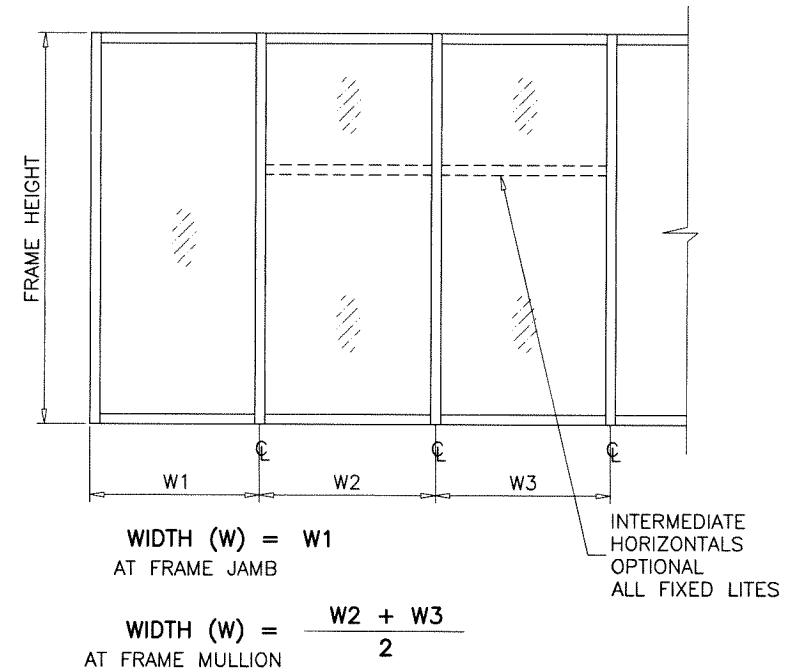

SEE SHEET 12 FOR ANCHOR TYPES.

Sealed: 8/19/2025



HEAD/SILL ANCHORS

FL #19973

**af c**

**AL-FAROOQ CORPORATION**  
ENGINEERS & PRODUCT DEVELOPMENT  
9360 SUNSET DRIVE, SUITE 220  
MIAMI, FLORIDA 33173 (C.A.N. 3538)  
TEL. (305) 264-8100 FAX. (305) 262-6978  
COMP-ANL 21-51FAGP

SERIES FRONT SET ALUM WINDOW WALL SYS. (L.M.I.)

**Aldora Aluminum & Glass Products Inc.**  
4250 Coral Ridge Drive, Suite 101  
Coral Springs, FL. 33065  
Tel. (954) 784-6900 Fax. (954) 784-6901

revisions:	no	date	by	description
date:	06-10-21	scale:		
dr. by:	TARIQ	chk. by:		
drawing no.	21-51F			
sheet	14 of 27			

JAMB ANCHOR LOAD CAPACITY - PSF EXT.(+) & INT.(-)							
NOMINAL DIMS.		ANCHORS 'AW', 'AC'		ANCHORS TYPES 'CM'		ANCHORS TYPES 'BW' & 'BC'	
WIDTH (W)	FRAME HEIGHT	1/4" SHIMS	3/8" SHIMS	1/4" SHIMS	3/8" SHIMS	1/4" SHIMS	3/8" SHIMS
30"	84"	135.0	135.0	135.0	135.0	135.0	135.0
36"		135.0	135.0	135.0	135.0	135.0	135.0
42"		135.0	135.0	135.0	135.0	135.0	135.0
48"		135.0	135.0	135.0	135.0	135.0	135.0
54"		135.0	131.5	135.0	135.0	135.0	135.0
60"		135.0	124.9	135.0	135.0	135.0	135.0
66"		135.0	120.2	135.0	135.0	135.0	135.0
72"		135.0	117.1	135.0	135.0	135.0	135.0
30"	90"	135.0	135.0	135.0	135.0	135.0	135.0
36"		135.0	135.0	135.0	135.0	135.0	135.0
42"		135.0	135.0	135.0	135.0	135.0	135.0
48"		135.0	135.0	135.0	135.0	135.0	135.0
54"		135.0	135.0	135.0	135.0	135.0	135.0
60"		135.0	128.4	135.0	135.0	135.0	135.0
66"		135.0	122.9	135.0	135.0	135.0	135.0
72"		135.0	118.9	135.0	135.0	135.0	135.0
30"	96"	135.0	135.0	135.0	135.0	135.0	135.0
36"		135.0	135.0	135.0	135.0	135.0	135.0
42"		135.0	135.0	135.0	135.0	135.0	135.0
48"		135.0	133.8	135.0	135.0	135.0	135.0
54"		135.0	124.1	135.0	135.0	135.0	135.0
60"		135.0	116.8	135.0	135.0	135.0	135.0
66"		135.0	111.2	135.0	135.0	135.0	135.0
72"		133.3	107.0	133.3	135.0	135.0	135.0
30"	102"	135.0	135.0	135.0	135.0	135.0	135.0
36"		135.0	135.0	135.0	135.0	135.0	135.0
42"		135.0	135.0	135.0	135.0	135.0	135.0
48"		135.0	135.0	135.0	135.0	135.0	135.0
54"		135.0	128.4	135.0	135.0	135.0	135.0
60"		135.0	120.4	135.0	135.0	135.0	135.0
66"		135.0	114.2	135.0	135.0	135.0	135.0
72"		135.0	109.5	135.0	135.0	135.0	135.0
30"	108"	135.0	135.0	135.0	135.0	135.0	135.0
36"		135.0	135.0	135.0	135.0	135.0	135.0
42"		135.0	135.0	135.0	135.0	135.0	135.0
48"		135.0	129.0	135.0	135.0	135.0	135.0
54"		135.0	118.9	135.0	135.0	135.0	135.0
60"		135.0	111.2	135.0	135.0	135.0	135.0
66"		130.9	105.1	130.9	135.0	135.0	135.0
72"		125.0	100.4	125.0	130.6	135.0	135.0
30"	114"	135.0	135.0	135.0	135.0	135.0	135.0
36"		135.0	135.0	135.0	135.0	135.0	135.0
42"		135.0	135.0	135.0	135.0	135.0	135.0
48"		135.0	133.8	135.0	135.0	135.0	135.0
54"		135.0	123.0	135.0	135.0	135.0	135.0
60"		135.0	114.7	135.0	135.0	135.0	135.0
66"		134.7	108.1	134.7	135.0	135.0	135.0
72"		128.2	102.9	128.2	133.9	135.0	135.0
30"	120"	135.0	135.0	135.0	135.0	135.0	135.0
36"		135.0	135.0	135.0	135.0	135.0	135.0
42"		135.0	135.0	135.0	135.0	135.0	135.0
48"		135.0	125.4	135.0	135.0	135.0	135.0
54"		135.0	115.1	135.0	135.0	135.0	135.0
60"		133.3	107.0	133.3	135.0	135.0	135.0
66"		125.4	100.7	125.4	131.0	135.0	135.0
72"		119.0	95.6	119.0	124.3	135.0	135.0

JAMB ANCHOR LOAD CAPACITY - PSF EXT.(+) & INT.(-)							
NOMINAL DIMS.		ANCHORS 'AW', 'AC'		ANCHORS TYPES 'CM'		ANCHORS TYPES 'BW' & 'BC'	
WIDTH (W)	FRAME HEIGHT	1/4" SHIMS	3/8" SHIMS	1/4" SHIMS	3/8" SHIMS	1/4" SHIMS	3/8" SHIMS
30"	126"	135.0	135.0	135.0	135.0	135.0	135.0
36"		135.0	135.0	135.0	135.0	135.0	135.0
42"		135.0	135.0	135.0	135.0	135.0	135.0
48"		135.0	129.9	135.0	135.0	135.0	135.0
54"		135.0	118.9	135.0	135.0	135.0	135.0
60"		135.0	110.4	135.0	135.0	135.0	135.0
66"		129.0	103.6	129.0	134.8	135.0	135.0
72"		122.2	98.1	122.2	127.6	135.0	135.0
30"	132"	135.0	135.0	135.0	135.0	135.0	135.0
36"		135.0	135.0	135.0	135.0	135.0	135.0
42"		135.0	135.0	135.0	135.0	135.0	135.0
48"		135.0	122.7	135.0	135.0	135.0	135.0
54"		135.0	112.1	135.0	135.0	135.0	135.0
60"		129.4	103.9	129.4	135.0	135.0	135.0
66"		121.2	97.3	121.2	126.6	135.0	135.0
72"		114.6	92.0	114.6	119.7	135.0	135.0
30"	138"	135.0	135.0	135.0	135.0	135.0	135.0
36"		135.0	135.0	135.0	135.0	135.0	135.0
42"		135.0	135.0	135.0	135.0	135.0	135.0
48"		135.0	126.8	135.0	135.0	135.0	135.0
54"		135.0	115.7	135.0	135.0	135.0	135.0
60"		133.3	107.0	133.3	135.0	135.0	135.0
66"		124.7	100.1	124.7	130.2	135.0	135.0
72"		117.6	94.4	117.6	122.9	135.0	135.0
30"	144"	135.0	135.0	135.0	135.0	135.0	135.0
36"		135.0	135.0	135.0	135.0	135.0	135.0
42"		135.0	134.3	135.0	135.0	135.0	135.0
48"		135.0	120.4	135.0	135.0	135.0	135.0
54"		135.0	109.8	135.0	135.0	135.0	135.0
60"		126.3	101.4	126.3	131.9	135.0	135.0
66"		117.9	94.7	117.9	123.2	135.0	135.0
72"		111.1	89.2	111.1	116.0	135.0	135.0

INTERPOLATION BETWEEN WIDTHS OR HEIGHTS ALLOWED.

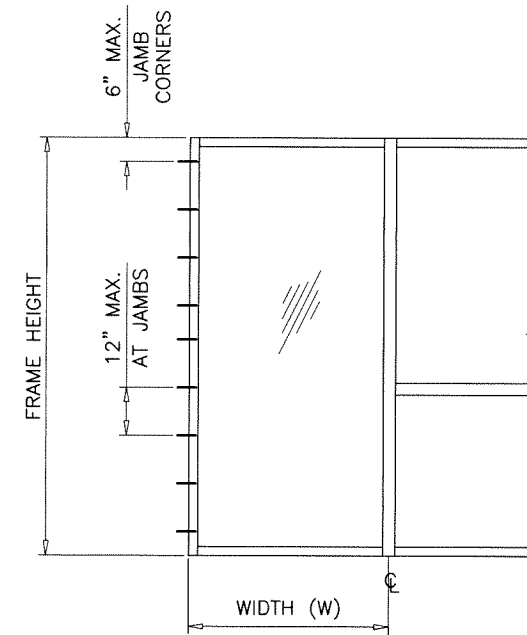

SEE SHEET 12 FOR ANCHOR TYPES.

Sealed: 8/19/2025

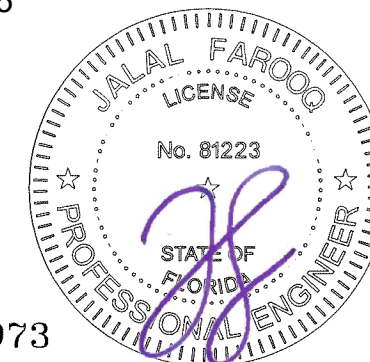

JAMB ANCHORS

FL #19973

**af c**  
**AL-FAROOQ CORPORATION**  
 ENGINEERS & PRODUCT DEVELOPMENT  
 9360 SUNSET DRIVE, SUITE 220  
 MIAMI, FLORIDA 33173 (C.A.N. 3538)  
 TEL. (305) 264-8100 FAX. (305) 262-6978  
 COMP-ANL/21-51FAGP

SERIES FRONT SET ALUM WINDOW WALL SYS. (L.M.I.)  
**Aldora Aluminum & Glass Products Inc.**  
 4250 Coral Ridge Drive, Suite 101  
 Coral Springs, FL 33065  
 Tel. (954) 784-6900 Fax. (954) 784-6901

revisions:	no.	date	by	description
date:	06-10-21	scale:	-	dr. by: TARIQ
				chk. by:
drawing no.	21-51F			
sheet	15 of 27			



H.D. DOOR MULLION LOAD CAPACITY		
NOMINAL DIMS.		WITH REINF.
WIDTH (W)	FRAME HEIGHT	EXT.(+) & INT.(-)
30"	126"	100.0
36"		100.0
42"		100.0
48"		100.0
54"		100.0
60"	100.0	
30"	132"	100.0
36"		100.0
42"		100.0
48"		100.0
54"		100.0
60"	100.0	
30"	138"	100.0
36"		100.0
42"		100.0
48"		100.0
54"		100.0
57"	100.0	
30"	144"	100.0
36"		100.0
42"		100.0
48"		100.0
54"		100.0

INTERPOLATION BETWEEN WIDTHS OR HEIGHTS ALLOWED.

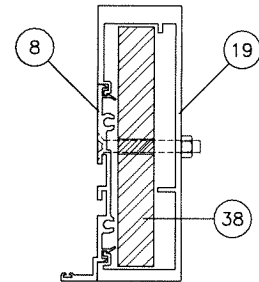

H.D. DOOR MULLION WITH REINF.  
(LEVEL 'D' & 'E' IMPACT)

	Ix IN <sup>4</sup>	Sx IN <sup>3</sup>
ALUMINUM	11.342	3.497
STEEL	7.8125	3.125
TOTAL Ix ALUM + Ix STL X 2.9	33.7739	

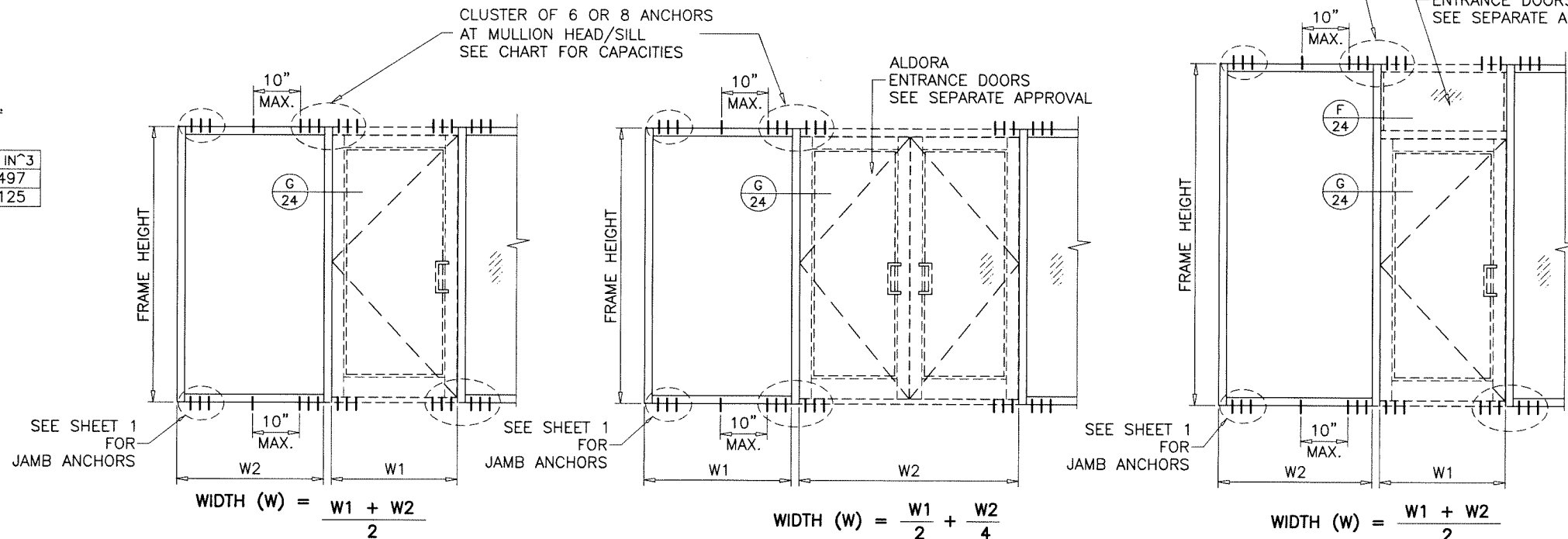

DOOR MULLION ANCHORS LOAD CAPACITY - PSF								
NOMINAL DIMS.		6 ANCHORS AT MULLION ENDS				8 ANCHORS AT MULLION ENDS		
		1/4" MAX. SHIMS		3/8" SHIMS		1/4" MAX. SHIMS		3/8" SHIMS
		ANCHOR TYPES 'AW' & 'AC'	ANCHOR TYPES 'CM'	ANCHOR TYPES 'BW' & 'BC'	ANCHOR TYPES 'BW' & 'BC'	ANCHOR TYPES 'AW' & 'AC'	ANCHOR TYPES 'BW' & 'BC'	ANCHOR TYPES 'BW' & 'BC'
WIDTH (W)	FRAME HEIGHT	EXT. (+) INT. (-)	EXT. (+) INT. (-)	EXT. (+) INT. (-)	EXT. (+) INT. (-)	EXT. (+) INT. (-)	EXT. (+) INT. (-)	EXT. (+) INT. (-)
30"	126"	100.0	100.0	100.0	100.0	100.0	100.0	100.0
36"		99.0	100.0	100.0	99.4	100.0	100.0	100.0
42"		84.9	100.0	100.0	85.2	100.0	100.0	100.0
48"		74.3	100.0	97.7	74.6	99.0	100.0	99.4
54"		66.0	97.3	86.9	66.3	88.0	100.0	88.4
60"	59.4	87.5	78.2	59.7	79.2	100.0	79.5	
30"	132"	100.0	100.0	100.0	100.0	100.0	100.0	100.0
36"		94.5	100.0	100.0	94.9	100.0	100.0	100.0
42"		81.0	100.0	100.0	81.4	100.0	100.0	100.0
48"		70.9	100.0	93.3	71.2	94.5	100.0	94.9
54"		63.0	92.8	82.9	63.3	84.0	100.0	84.4
60"	56.7	83.6	74.6	56.9	75.6	99.5	75.9	
30"	138"	100.0	100.0	100.0	100.0	100.0	100.0	100.0
36"		90.4	100.0	100.0	90.8	100.0	100.0	100.0
42"		77.5	100.0	100.0	77.8	100.0	100.0	100.0
48"		67.8	99.9	89.2	68.1	90.4	100.0	90.8
54"		60.3	88.8	79.3	60.5	80.4	100.0	80.7
57"	57.1	84.1	75.1	57.3	76.2	100.0	76.4	
30"	144"	100.0	100.0	100.0	100.0	100.0	100.0	100.0
36"		86.7	100.0	100.0	87.0	100.0	100.0	100.0
42"		74.3	100.0	97.7	74.6	99.0	100.0	99.4
48"		65.0	95.8	85.5	65.3	86.7	100.0	87.0
54"		57.8	85.1	76.0	58.0	77.0	100.0	77.3

INTERPOLATION BETWEEN WIDTHS OR HEIGHTS ALLOWED.

DOOR MULLION

FL #19973

Sealed: 8/19/2025

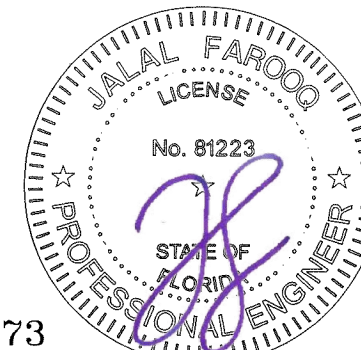

**AL-FAROOQ CORPORATION**  
 ENGINEERS & PRODUCT DEVELOPMENT  
 9360 SUNSET DRIVE, SUITE 220  
 MIAMI, FLORIDA 33173  
 TEL. (305) 264-8100 FAX. (305) 262-6978

SERIES FRONT SET ALUM WINDOW WALL SYS. (L.M.I.)  
**Adora Aluminum & Glass Products Inc.**  
 4250 Coral Ridge Drive, Suite 101  
 Coral Springs, FL. 33065  
 Tel. (954) 784-6900 Fax. (954) 784-6901

revisions:  
 no. date by description

date: 06-10-21  
 scale: -  
 dr. by: TARIQ  
 chk. by:

drawing no.  
**21-51F**  
 sheet 17 of 27

COMP-ANL\21-51FAGP

STD. DOOR MULLION LOAD CAPACITY - PSF				
NOMINAL DIMS.				WITH REINF.
FRAME HEIGHT INCHES	DOOR HEIGHT INCHES	WIDTH (W1) INCHES	WIDTH (W2) INCHES	EXT. (+) INT. (-)
108	84	84	30	97.1
			36	91.6
			42	86.8
			48	82.4
			54	78.4
			60	74.8
	98-7/16	84	30	86.6
			36	82.2
			42	78.3
			48	74.7
			54	71.5
			60	68.5
120	84	84	30	74.0
			36	70.1
			42	66.6
			48	63.4
			54	60.5
			60	57.9
	98-7/16	84	30	65.9
			36	62.8
			42	59.9
			48	57.3
			54	55.0
			60	52.8
108	96	84	30	100.0
			36	100.0
			42	97.5
			48	92.0
			54	87.1
			60	82.7
	98-7/16	84	30	99.4
			36	93.7
			42	88.6
			48	84.1
			54	80.0
			60	76.2
120	96	84	30	80.3
			36	75.7
			42	71.6
			48	68.0
			54	64.6
			60	61.6
	98-7/16	84	30	71.7
			36	68.1
			42	64.7
			48	61.7
			54	59.0
			60	56.5

INTERPOLATION BETWEEN WIDTHS OR HEIGHTS ALLOWED.

DOOR MULLION ANCHORS LOAD CAPACITY - PSF										
NOMINAL DIMS.				1/4" MAX. SHIMS			3/8" MAX. SHIMS			
				ANCHOR TYPES 'AW' & 'AC'	ANCHOR TYPES 'CM'	ANCHOR TYPES 'BW' & 'BC'	ANCHOR TYPES 'BW' & 'BC'	ANCHOR TYPES 'CM'	ANCHOR TYPES 'BW' & 'BC'	
FRAME HEIGHT INCHES	DOOR HEIGHT INCHES	WIDTH (W1) INCHES	WIDTH (W2) INCHES	EXT. (+) INT. (-)	EXT. (+) INT. (-)	EXT. (+) INT. (-)	EXT. (+) INT. (-)	EXT. (+) INT. (-)	EXT. (+) INT. (-)	
108	84	84	30	100.0	100.0	100.0	81.8	75.9	100.0	
			36	100.0	100.0	100.0	77.4	71.8	100.0	
			42	95.1	100.0	100.0	73.4	68.1	95.5	
			48	90.4	100.0	100.0	69.8	64.8	90.8	
			54	86.2	100.0	100.0	66.6	61.8	86.5	
			60	82.4	100.0	100.0	63.6	59.0	82.7	
		98-7/16	84	30	94.4	100.0	100.0	72.9	67.6	94.8
				36	89.8	100.0	100.0	69.4	64.3	90.2
				42	85.7	100.0	100.0	66.1	61.4	86.0
				48	81.9	100.0	100.0	63.2	58.6	82.2
				54	78.4	100.0	100.0	60.5	56.2	78.7
				60	75.2	100.0	98.9	58.1	53.9	75.5
	120	84	84	30	98.5	100.0	100.0	76.0	70.5	98.8
				36	93.0	100.0	100.0	71.8	66.6	93.3
				42	88.0	100.0	100.0	68.0	63.1	88.4
				48	83.6	100.0	100.0	64.6	59.9	83.9
				54	79.6	100.0	100.0	61.5	57.0	79.9
				60	76.0	100.0	99.9	58.7	54.4	76.3
		98-7/16	84	30	87.8	100.0	100.0	67.8	62.9	88.2
				36	83.4	100.0	100.0	64.4	59.8	83.7
				42	79.4	100.0	100.0	61.3	56.9	79.8
				48	75.8	100.0	99.7	58.5	54.3	76.1
				54	72.5	100.0	95.4	56.0	51.9	72.8
				60	69.5	100.0	91.4	53.7	49.8	69.8
108	96	84	30	100.0	100.0	100.0	78.3	72.7	100.0	
			36	96.2	100.0	100.0	74.3	68.9	96.6	
			42	91.4	100.0	100.0	70.6	65.5	91.8	
			48	87.1	100.0	100.0	67.3	62.4	87.5	
			54	83.2	100.0	100.0	64.2	59.6	83.5	
			60	79.6	100.0	100.0	61.5	57.0	79.9	
		98-7/16	84	30	90.2	100.0	100.0	69.7	64.6	90.6
				36	86.0	100.0	100.0	66.4	61.6	86.3
				42	82.2	100.0	100.0	63.5	58.9	82.5
				48	78.7	100.0	100.0	60.8	56.4	79.0
				54	75.5	100.0	99.3	58.3	54.1	75.8
				60	72.5	100.0	95.4	56.0	51.9	72.8
	120	96	84	30	94.5	100.0	100.0	73.0	67.7	94.9
				36	89.5	100.0	100.0	69.1	64.1	89.8
				42	84.9	100.0	100.0	65.6	60.8	85.2
				48	80.8	100.0	100.0	62.4	57.9	81.1
				54	77.0	100.0	100.0	59.5	55.2	77.3
				60	73.6	100.0	96.8	56.8	52.7	73.9
		98-7/16	84	30	84.2	100.0	100.0	65.0	60.3	84.5
				36	80.1	100.0	100.0	61.9	57.4	80.4
				42	76.5	100.0	100.0	59.0	54.8	76.7
				48	73.1	100.0	96.1	56.4	52.4	73.4
				54	70.0	100.0	92.1	54.1	50.2	70.3
				60	67.2	99.0	88.4	51.9	48.1	67.4

INTERPOLATION BETWEEN WIDTHS OR HEIGHTS ALLOWED.

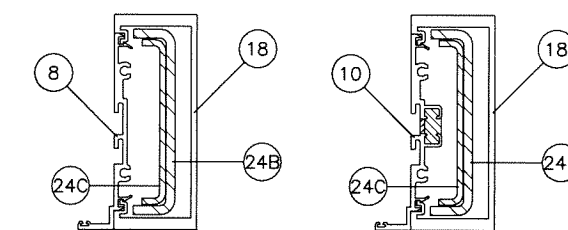
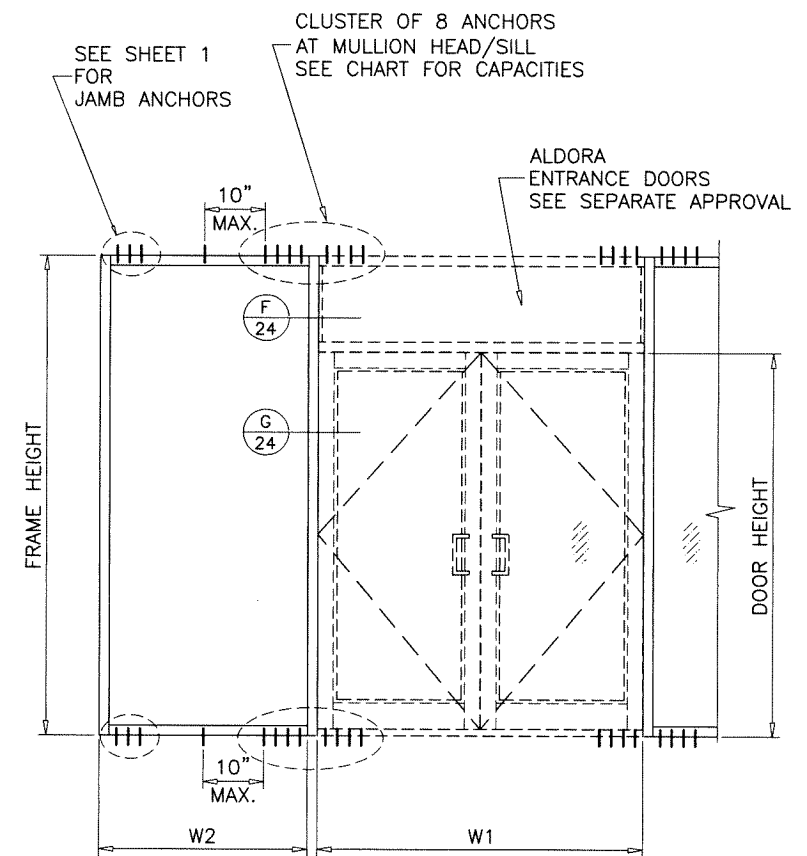

STD. DOOR MULLION WITH REINF.  
(LEVEL 'D' & 'E' IMPACT)

	Ix IN <sup>4</sup>	Sx IN <sup>3</sup>
ALUMINUM	6.063	2.695
STEEL	2.343	1.209
TOTAL Ix ALUM + Ix STL X 2.9	12.790	

Sealed: 8/19/2025

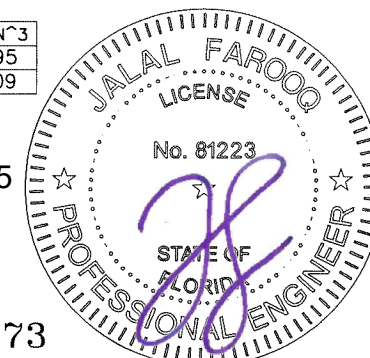

DOOR MULLION

FL #19973

**af c**  
**AL-FAROOQ CORPORATION**  
 ENGINEERS & PRODUCT DEVELOPMENT  
 9360 SUNSET DRIVE, SUITE 220  
 MIAMI, FLORIDA 33173 (C.A.N. 3538)  
 TEL. (305) 264-8100 FAX. (305) 262-6978  
 COMP-ANL 21-51FAGP

SERIES FRONT SET ALUM WINDOW WALL SYS. (L.M.I.)  
**Aldora Aluminum & Glass Products Inc.**  
 4250 Coral Ridge Drive, Suite 101  
 Coral Springs, FL. 33065  
 Tel. (954) 784-6900 Fax. (954) 784-6901

no	date	description

date: 06-10-21  
 scale: -  
 dr. by: TARIQ  
 chk. by:

drawing no.  
**21-51F**  
 sheet 18 of 27

H.D. DOOR MULLION LOAD CAPACITY - PSF					
NOMINAL DIMS.				WITH REINF.	
FRAME HEIGHT INCHES	DOOR HEIGHT INCHES	WIDTH (W1) INCHES	WIDTH (W2) INCHES	EXT. (+) INT. (-)	
144	84	84	30	100.0	
			36	95.0	
			42	90.5	
			48	86.3	
			54	82.5	
			60	79.1	
		92	30	93.5	
			36	89.1	
			42	85.1	
			48	81.4	
			54	78.0	
			60	74.9	
	98-7/16	92	30	88.9	
			36	84.9	
			42	81.2	
			48	77.8	
			54	74.7	
			60	71.9	
		98-7/16	30	88.9	
			36	84.9	
			42	81.2	
			48	77.8	
			54	74.7	
			60	71.9	
	144	96	84	30	100.0
				36	97.9
				42	93.1
				48	88.7
				54	84.7
				60	81.0
			92	30	96.6
				36	91.9
				42	87.6
				48	83.7
				54	80.1
				60	76.9
98-7/16		92	30	91.8	
			36	87.6	
			42	83.7	
			48	80.1	
			54	76.8	
			60	73.8	
		98-7/16	30	91.8	
			36	87.6	
			42	83.7	
			48	80.1	
			54	76.8	
			60	73.8	
108		84	84	30	100.0
				36	100.0
				42	97.8
				48	92.9
				54	88.6
				60	84.6
			92	30	100.0
				36	96.9
				42	92.2
				48	87.9
				54	84.0
				60	80.4
	98-7/16	92	30	97.2	
			36	92.5	
			42	88.1	
			48	84.2	
			54	80.6	
			60	77.3	
		98-7/16	30	97.2	
			36	92.5	
			42	88.1	
			48	84.2	
			54	80.6	
			60	77.3	

H.D. DOOR MULLION LOAD CAPACITY - PSF				
NOMINAL DIMS.				WITH REINF.
FRAME HEIGHT INCHES	DOOR HEIGHT INCHES	WIDTH (W1) INCHES	WIDTH (W2) INCHES	EXT. (+) INT. (-)
144	118-1/4	84	30	100.0
			36	100.0
			42	100.0
			48	98.5
			54	93.6
			60	89.1
		92	30	100.0
			36	100.0
			42	98.2
			48	93.3
			54	88.9
			60	84.9
144	118-1/4	92	30	100.0
			36	100.0
			42	98.2
			48	93.3
			54	88.9
			60	84.9
		98-7/16	30	100.0
			36	98.9
			42	94.0
			48	89.5
			54	85.5
			60	81.8

INTERPOLATION BETWEEN WIDTHS OR HEIGHTS ALLOWED.

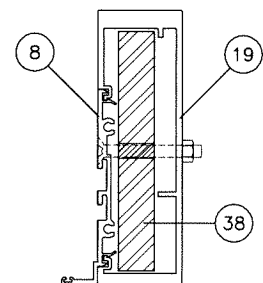

H.D. DOOR MULLION WITH REINF.  
(LEVEL 'D' & 'E' IMPACT)

	Ix IN <sup>4</sup>	Sx IN <sup>3</sup>
ALUMINUM	11.342	3.497
STEEL	7.8125	3.125
TOTAL Ix ALUM + Ix STL X 2.9	33.7739	

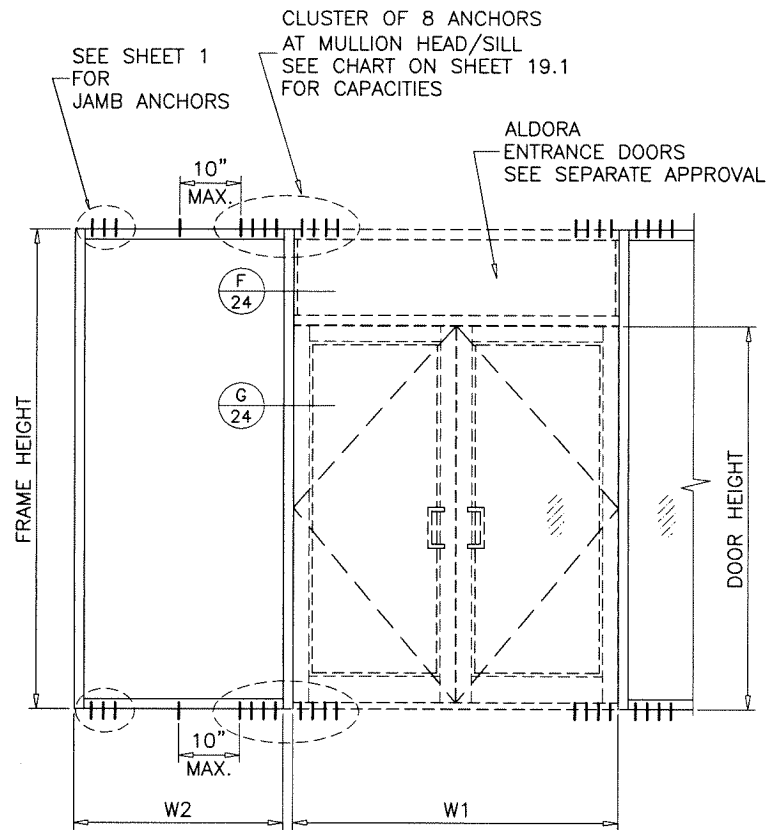

DOOR MULLION

Sealed: 8/19/2025



FL #19973

**af c**  
**AL-FAROOQ CORPORATION**  
 ENGINEERS & PRODUCT DEVELOPMENT  
 9360 SUNSET DRIVE, SUITE 220 (C.A.N. 3538)  
 MIAMI, FLORIDA 33173  
 TEL. (305) 264-8100 FAX. (305) 262-6978  
 COMP-ANL\21-51FAGP

SERIES FRONT SET ALUM WINDOW WALL SYS. (L.M.I.)  
**Aldora Aluminum & Glass Products Inc.**  
 4250 Coral Ridge Drive, Suite 101  
 Coral Springs, FL. 33065  
 Tel. (954) 784-6900 Fax. (954) 784-6901

revisions:	no.	date	by	description

  

date: 06-10-21	scale: -	dr. by: TARIQ	chk. by:
drawing no. 21-51F			
sheet 19 of 27			

DOOR MULLION ANCHORS LOAD CAPACITY - PSF									
NOMINAL DIMS.				1/4" MAX. SHIMS			3/8" MAX. SHIMS		
				ANCHOR TYPES 'AW' & 'AC'	ANCHOR TYPES 'CM'	ANCHOR TYPES 'BW' & 'BC'	ANCHOR TYPES 'BW' & 'BC'	ANCHOR TYPES 'CM'	ANCHOR TYPES 'BW' & 'BC'
FRAME HEIGHT INCHES	DOOR HEIGHT INCHES	WIDTH (W1) INCHES	WIDTH (W2) INCHES	EXT. (+) INT. (-)	EXT. (+) INT. (-)	EXT. (+) INT. (-)	EXT. (+) INT. (-)	EXT. (+) INT. (-)	EXT. (+) INT. (-)
144	84	84	30	86.2	100.0	100.0	66.6	61.8	86.5
			36	81.2	100.0	100.0	62.7	58.1	81.5
			42	76.7	100.0	100.0	59.2	54.9	77.0
			48	72.7	100.0	95.6	56.1	52.1	72.9
			54	69.0	100.0	90.8	53.3	49.5	69.3
			60	65.8	96.9	86.5	50.8	47.1	66.0
		92	30	80.9	100.0	100.0	62.5	58.0	81.2
			36	76.4	100.0	100.0	59.0	54.8	76.7
			42	72.5	100.0	95.3	55.9	51.9	72.7
			48	68.9	100.0	90.6	53.2	49.3	69.1
			54	65.6	96.6	86.3	50.6	47.0	65.9
			60	62.6	92.3	82.4	48.4	44.9	62.9
		98-7/16	30	77.1	100.0	100.0	59.5	55.2	77.4
			36	73.0	100.0	96.1	56.4	52.3	73.3
			42	69.4	100.0	91.3	53.6	49.7	69.6
			48	66.1	97.3	86.9	51.0	47.3	66.3
			54	63.1	92.9	83.0	48.7	45.2	63.3
			60	60.3	88.9	79.3	46.6	43.2	60.6
	96	84	30	83.2	100.0	100.0	64.2	59.6	83.5
			36	78.5	100.0	100.0	60.6	56.2	78.8
			42	74.3	100.0	97.7	57.4	53.2	74.6
			48	70.5	100.0	92.7	54.4	50.5	70.8
			54	67.1	98.8	88.3	51.8	48.1	67.4
			60	64.0	94.3	84.2	49.4	45.8	64.2
		92	30	78.0	100.0	100.0	60.2	55.9	78.3
			36	73.8	100.0	97.1	57.0	52.9	74.1
			42	70.1	100.0	92.2	54.1	50.2	70.4
			48	66.7	98.3	87.8	51.5	47.8	67.0
			54	63.7	93.8	83.8	49.2	45.6	63.9
			60	60.9	89.7	80.1	47.0	43.6	61.1
		98-7/16	30	74.3	100.0	97.7	57.3	53.2	74.6
			36	70.5	100.0	92.7	54.4	50.5	70.8
			42	67.1	98.8	88.2	51.8	48.1	67.3
			48	64.0	94.3	84.2	49.4	45.8	64.2
			54	61.2	90.1	80.5	47.2	43.8	61.4
			60	58.6	86.3	77.1	45.2	42.0	58.8
108	84	30	80.4	100.0	100.0	62.1	57.6	80.7	
		36	76.0	100.0	99.9	58.7	54.4	76.3	
		42	72.0	100.0	94.8	55.6	51.6	72.3	
		48	68.5	100.0	90.1	52.9	49.1	68.7	
		54	65.3	96.1	85.8	50.4	46.7	65.5	
		60	62.3	91.8	82.0	48.1	44.6	62.6	
	92	30	75.3	100.0	99.0	58.1	53.9	75.6	
		36	71.4	100.0	93.9	55.1	51.2	71.7	
		42	67.9	100.0	89.3	52.4	48.7	68.2	
		48	64.7	95.4	85.2	50.0	46.4	65.0	
		54	61.9	91.1	81.4	47.8	44.3	62.1	
		60	59.2	87.2	77.9	45.7	42.4	59.4	
	98-7/16	30	71.6	100.0	94.2	55.3	51.3	71.9	
		36	68.1	100.0	89.6	52.6	48.8	68.4	
		42	64.9	95.7	85.4	50.1	46.5	65.2	
		48	62.0	91.4	81.6	47.9	44.4	62.3	
		54	59.4	87.5	78.1	45.8	42.5	59.6	
		60	56.9	83.9	74.9	44.0	40.8	57.2	

DOOR MULLION ANCHORS LOAD CAPACITY - PSF									
NOMINAL DIMS.				1/4" MAX. SHIMS			3/8" MAX. SHIMS		
				ANCHOR TYPES 'AW' & 'AC'	ANCHOR TYPES 'CM'	ANCHOR TYPES 'BW' & 'BC'	ANCHOR TYPES 'BW' & 'BC'	ANCHOR TYPES 'CM'	ANCHOR TYPES 'BW' & 'BC'
FRAME HEIGHT INCHES	DOOR HEIGHT INCHES	WIDTH (W1) INCHES	WIDTH (W2) INCHES	EXT. (+) INT. (-)	EXT. (+) INT. (-)	EXT. (+) INT. (-)	EXT. (+) INT. (-)	EXT. (+) INT. (-)	EXT. (+) INT. (-)
144	118-1/4	84	30	78.1	100.0	100.0	60.3	56.0	78.4
			36	74.0	100.0	97.3	57.1	53.0	74.2
			42	70.2	100.0	92.4	54.2	50.3	70.5
			48	66.8	98.5	87.9	51.6	47.9	67.1
			54	63.8	93.9	83.9	49.2	45.7	64.0
			60	61.0	89.8	80.2	47.1	43.7	61.2
		92	30	73.1	100.0	96.2	56.5	52.4	73.4
			36	69.5	100.0	91.4	53.6	49.8	69.7
			42	66.2	97.4	87.0	51.1	47.4	66.4
			48	63.1	93.0	83.1	48.8	45.2	63.4
			54	60.4	89.0	79.4	46.6	43.3	60.6
			60	57.9	85.2	76.1	44.7	41.5	58.1
	98-7/16	84	30	69.5	100.0	91.5	53.7	49.8	69.8
			36	66.2	97.6	87.1	51.1	47.4	66.5
			42	63.2	93.1	83.1	48.8	45.3	63.4
			48	60.4	89.0	79.5	46.7	43.3	60.7
			54	57.9	85.3	76.2	44.7	41.5	58.1
			60	55.6	81.9	73.1	42.9	39.8	55.8

INTERPOLATION BETWEEN WIDTHS OR HEIGHTS ALLOWED.

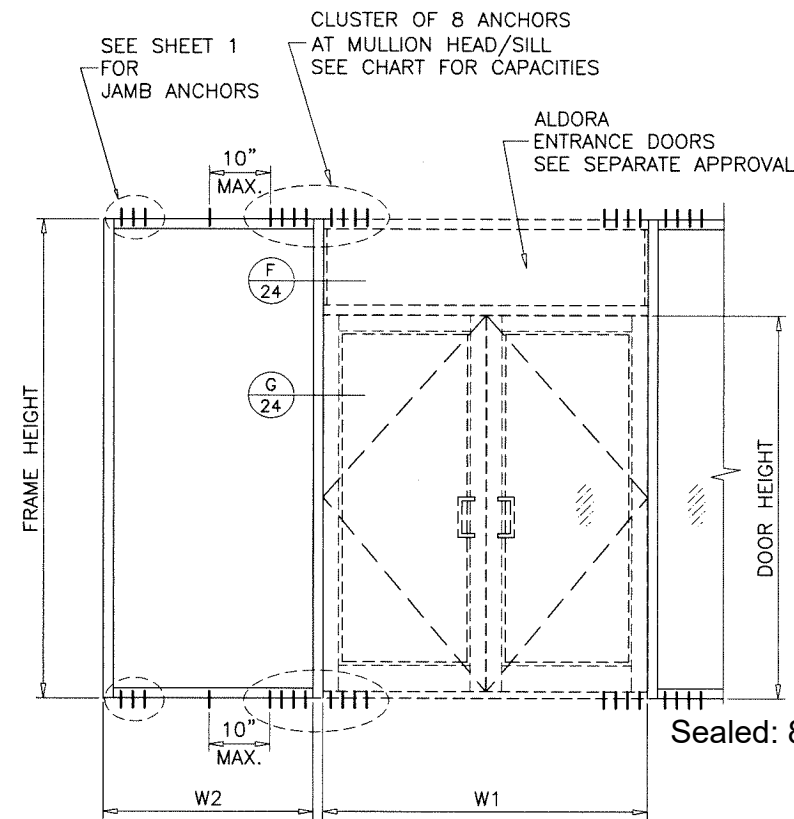

Sealed: 8/19/2025

DOOR MULLION

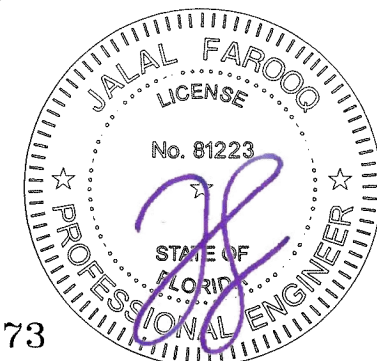

FL #19973

**af c**  
**AL-FAROOQ CORPORATION**  
 ENGINEERS & PRODUCT DEVELOPMENT  
 9360 SUNSET DRIVE, SUITE 220 (C.A.N. 3538)  
 MIAMI, FLORIDA 33173  
 TEL. (305) 264-8100 FAX. (305) 262-6978  
 COMP-ANL\21-51FAGT

SERIES FRONT SET ALUM WINDOW WALL SYS. (L.M.I.)  
**Aldora Aluminum & Glass Products Inc.**  
 4250 Coral Ridge Drive, Suite 101  
 Coral Springs, FL. 33065  
 Tel. (954) 784-6900 Fax. (954) 784-6901

revisions:	no	date	by	description
date:	06-10-21	scale:		
dr. by:	TARIQ	chk. by:		
drawing no.	21-51F			
sheet	19.1 of 27			

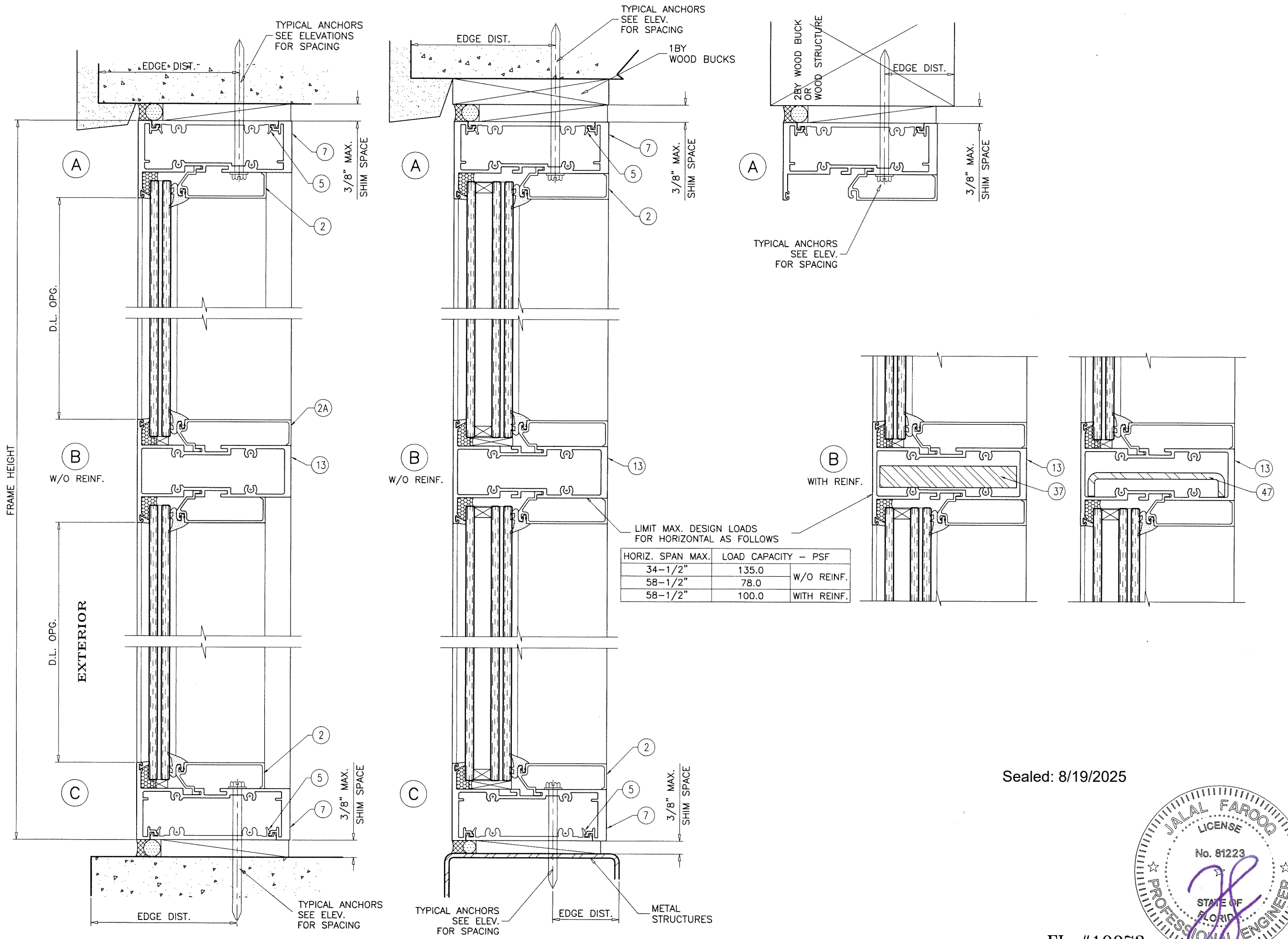

Sealed: 8/19/2025

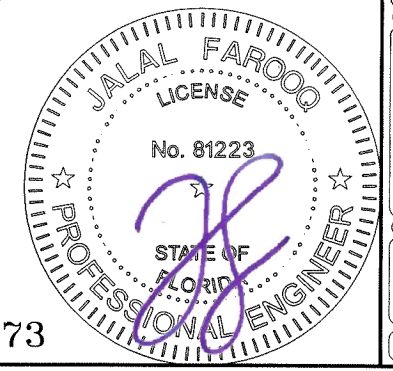

FL #19973

**afc**  
AL-FAROOQ CORPORATION  
ENGINEERS & PRODUCT DEVELOPMENT  
9360 SUNSET DRIVE, SUITE 220 (C.A.N. 3538)  
MIAMI, FLORIDA 33173  
TEL. (305) 264-8100 FAX. (305) 262-6978  
COMP-ANL 21-51FAGP

SERIES FRONT SET ALUM WINDOW WALL SYS. (L.M.I.)  
**Aldora Aluminum & Glass Products Inc.**  
4250 Coral Ridge Drive, Suite 101  
Coral Springs, FL. 33065  
Tel. (954) 784-6900 Fax. (954) 784-6901

revisions:	no	date	by	description
date:	06-10-21	scale:	3/8" = 1"	
dr. by:	TARIQ	chk. by:		
drawing no.	21-51F			
sheet	20 of 27			



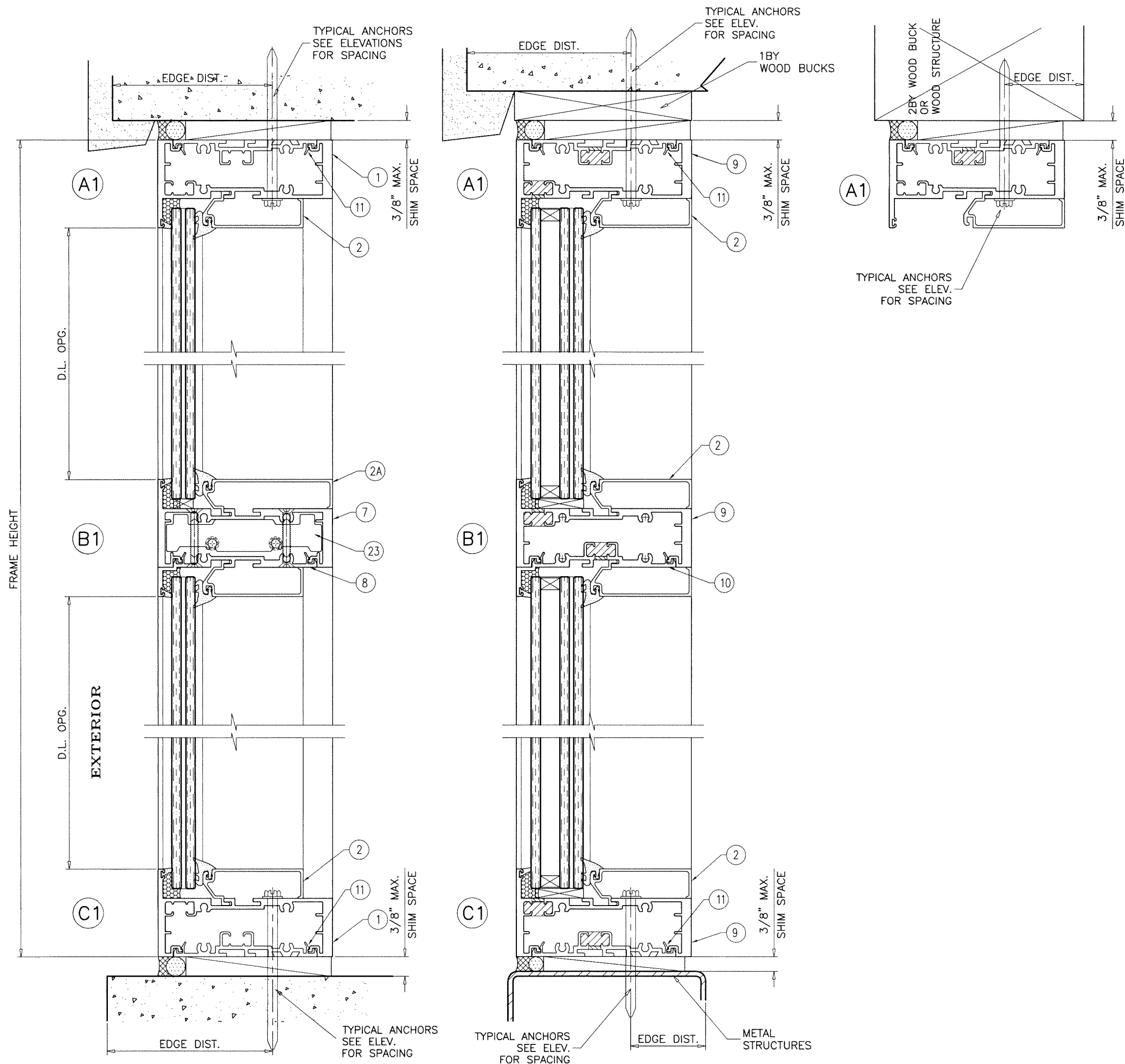

Sealed: 8/19/2025

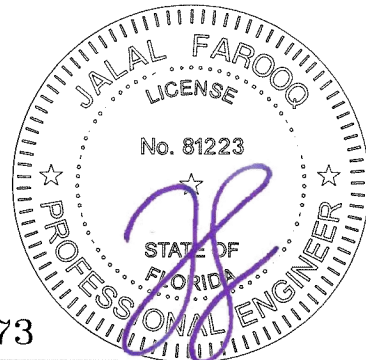

FL #19973

**af c**  
**AL-FAROOQ CORPORATION**  
 ENGINEERS & PRODUCT DEVELOPMENT  
 9360 SUNSET DRIVE, SUITE 220 (C.A.N. 3538)  
 MIAMI, FLORIDA 33173  
 TEL. (305) 264-8100 FAX. (305) 262-6978  
 COMP-ANL 21-51FAGP

SERIES FRONT SET ALUM WINDOW WALL SYS. (L.M.I.)  
**Aldora Aluminum & Glass Products Inc.**  
 4250 Coral Ridge Drive, Suite 101  
 Coral Springs, FL. 33065  
 Tel. (954) 784-6900 Fax. (954) 784-6901

no	date	by	description

date: 06-10-21  
 scale: 3/8" = 1"  
 dr. by: TARIQ  
 chk. by:   
 drawing no. 21-51F  
 sheet 22 of 27

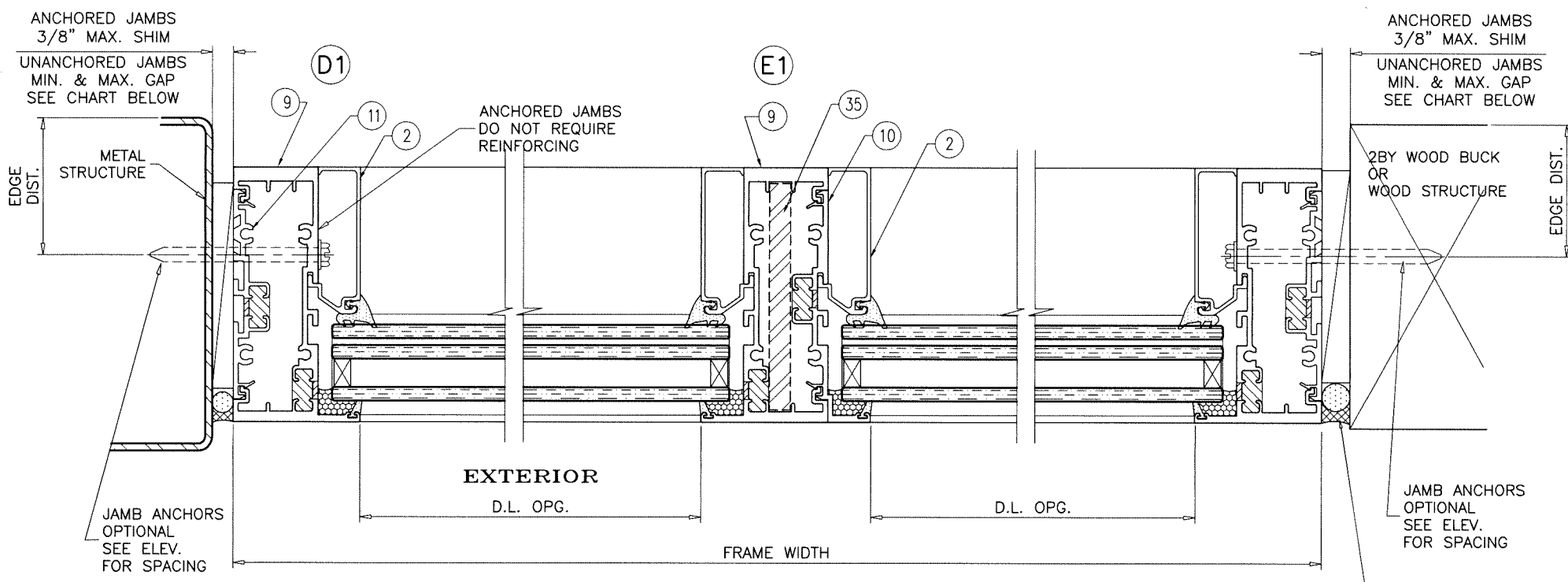
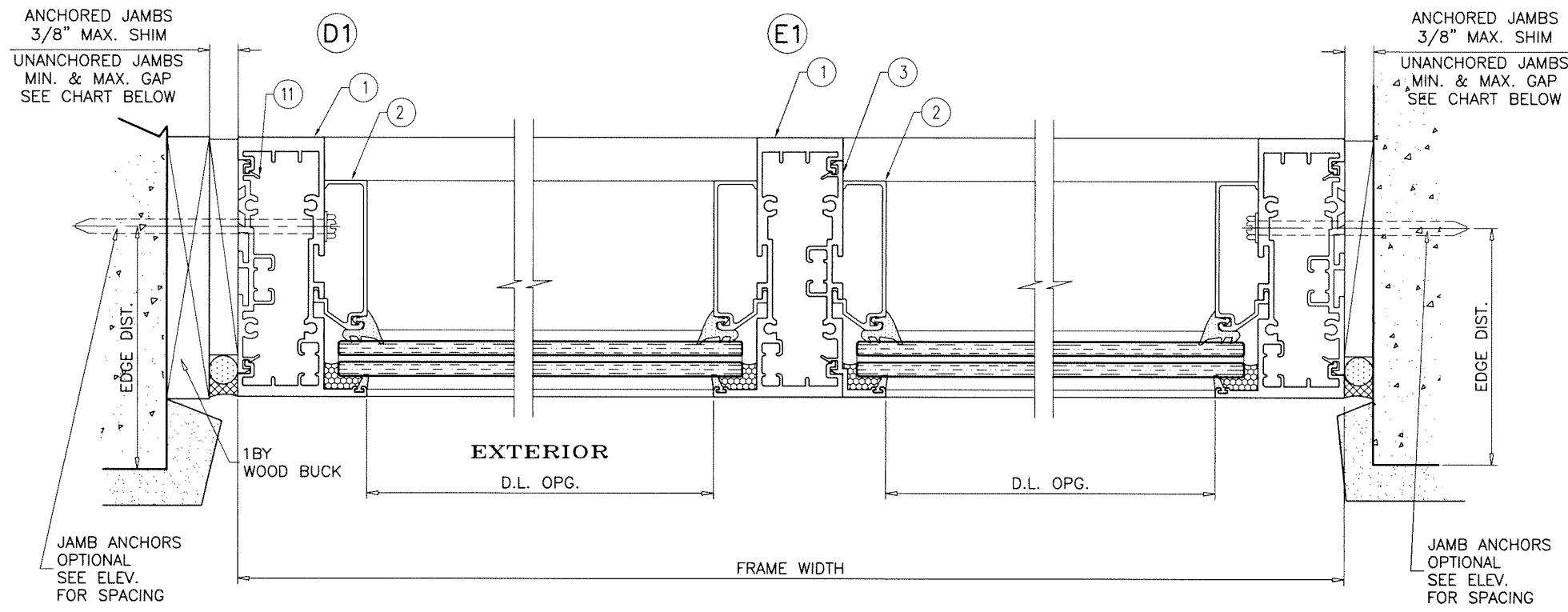

SILICONE AT UNANCHORED JAMBS  
DOWSIL 790  
DEPTH = 3/8" MIN.

MAX. FRAME HEIGHT	MAX. GAPS FOR UNANCHORED JAMBS			
	MULLION M1, M3 JAMB J1, J2, J3, J5		MULLION M2, M4 JAMB J2, J4	
	MIN.	MAX.	MIN.	MAX.
84"	1/4"	1"	1/4"	1"
96"	1/4"	1"	1/4"	1"
108"	1/4"	1"	3/8"	1"
120"	1/4"	1"	3/8"	1"
132"	-	-	3/8"	1"
144"	-	-	3/8"	1"

NOTE:  
MAX. MOVEMENT CONSIDERED=100% STRETCH.  
PLEASE REFER TO SEALANT MANUFACTURER'S DATA AND APPLICATION MANUAL FOR COMPATABILITY OF SEALANT TO SUBSTRATE & WINDOWALL MATERIAL/FINISH AND COMPLIANCE FOR WARRANTY.  
REFER TO ACI-117-10 FOR CONSTRUCTION TOLERANCES.  
ALTERNATE SEALANTS AT JAMB GAPS CAN BE DESIGNED BY ENGINEER OF RECORD BASED ON MANUFACTURER GUIDE LINES.  
GAPS LESS THAN 1/4" MAY BE DESIGNED BY ENGINEER OF RECORD BY THE USE OF BOND BREAKER TAPE OR 15% OF GAP ALLOWED MOVEMENT.  
REFER TO SHEETS 4 THRU 7 FOR SELECTION OF MULLION/JAMB WITH REINFORCED & UNREINFORCED FRAMES.

Sealed: 8/19/2025



FL #19973

**AL-FAROOQ CORPORATION**  
ENGINEERS & PRODUCT DEVELOPMENT  
9360 SUNSET DRIVE, SUITE 220  
MIAMI, FLORIDA 33173  
TEL. (305) 264-8100 FAX. (305) 262-6978  
C.A.N. 3538

SERIES FRONT SET ALUM WINDOWALL SYS. (L.M.I.)  
**Aldora Aluminum & Glass Products Inc.**  
4250 Coral Ridge Drive, Suite 101  
Coral Springs, FL 33065  
Tel. (954) 784-6900 Fax. (954) 784-6901

no	date	by	description

date: 06-10-21  
scale: 3/8" = 1"  
dr. by: TARIQ  
chk. by:

drawing no.  
**21-51F**  
sheet 23 of 27

SEE SEPARATE APPROVAL FOR DESIGN LOAD CAPACITY OF DOORS AND DOOR ANCHORS.

LOWER VALUES FROM DOORS APPROVAL OR STOREFRONT SYSTEM CAPACITY CHARTS WILL APPLY TO ENTIRE SYSTEM.

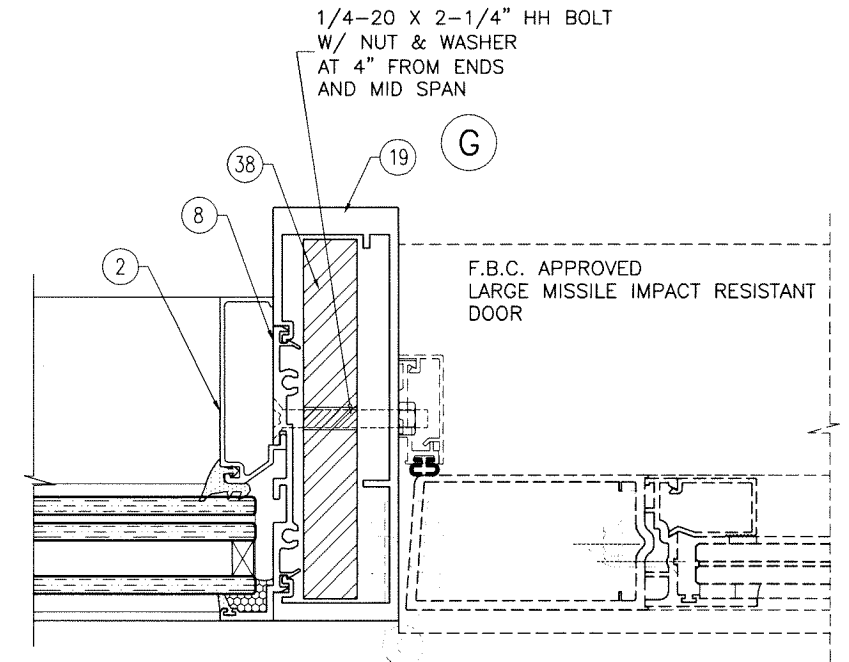
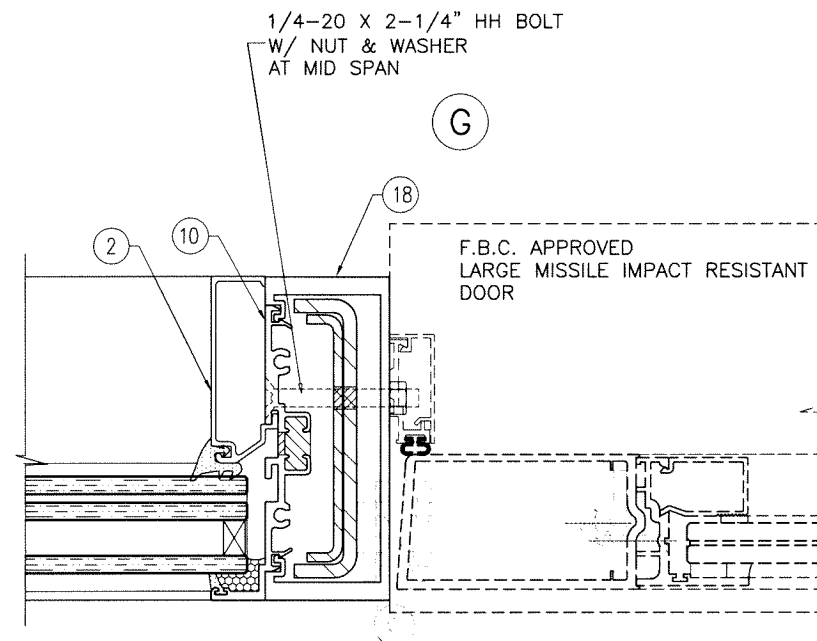
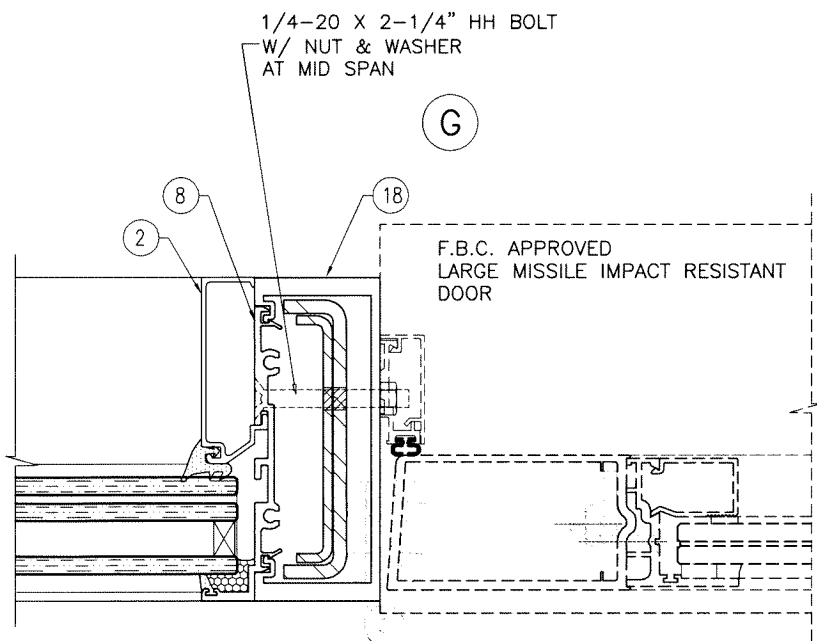
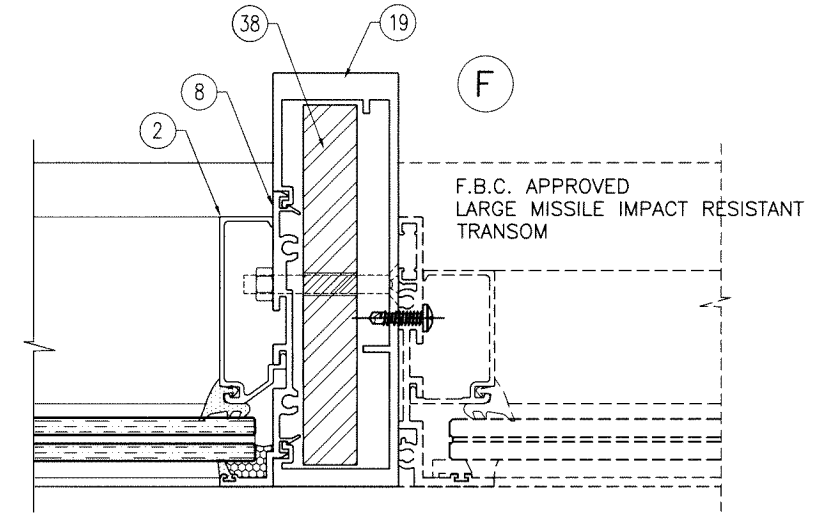
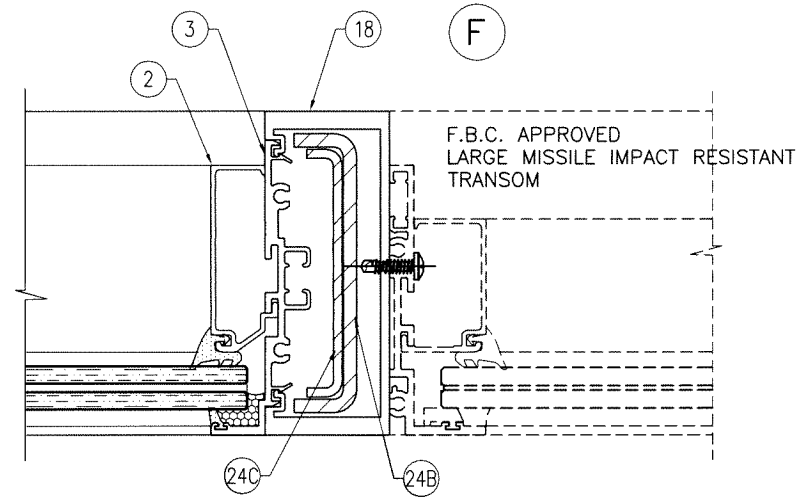
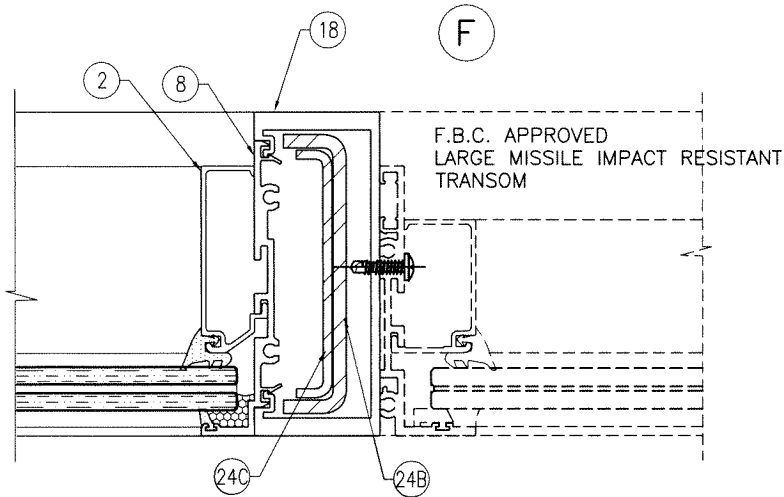

Sealed: 8/19/2025

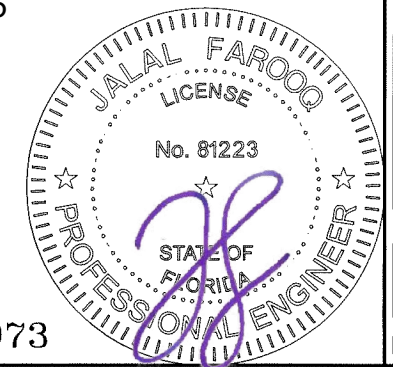

FL #19973

**af c**  
**AL-FAROOQ CORPORATION**  
 ENGINEERS & PRODUCT DEVELOPMENT  
 9360 SUNSET DRIVE, SUITE 220 (C.A.N. 3538)  
 MIAMI, FLORIDA 33173  
 TEL. (305) 264-8100 FAX. (305) 262-6978  
 COMP-ANL\21-51FAGP

SERIES FRONT SET ALUM WINDOW WALL SYS. (L.M.I.)  
**Aldora Aluminum & Glass Products Inc.**  
 4250 Coral Ridge Drive, Suite 101  
 Coral Springs, FL. 33065  
 Tel. (954) 784-6900 Fax. (954) 784-6901

revisions:

no	date	description

date: 06-10-21  
 scale: 3/8" = 1"  
 dr. by: TARIQ  
 chk. by:

drawing no.  
**21-51F**  
 sheet 24 of 27

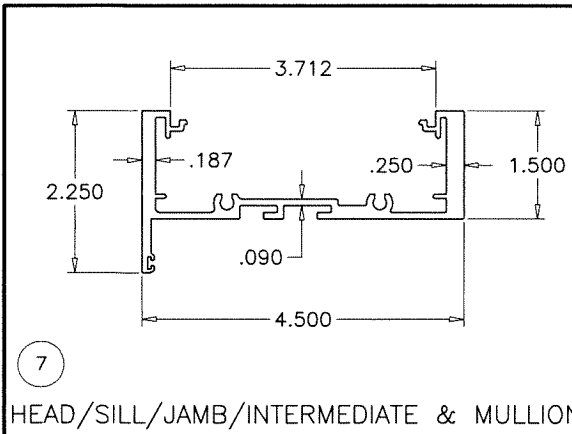

7 HEAD/SILL/JAMB/INTERMEDIATE & MULLION

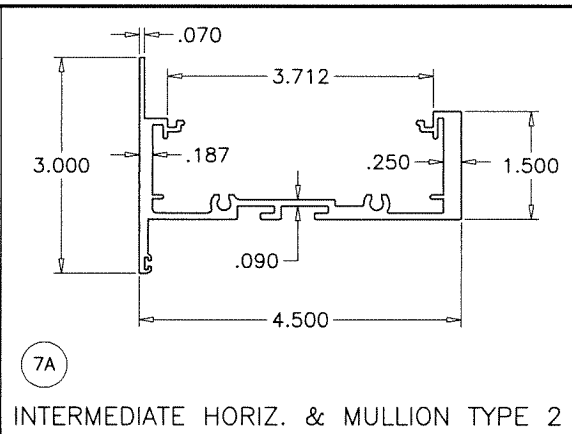

7A INTERMEDIATE HORIZ. & MULLION TYPE 2

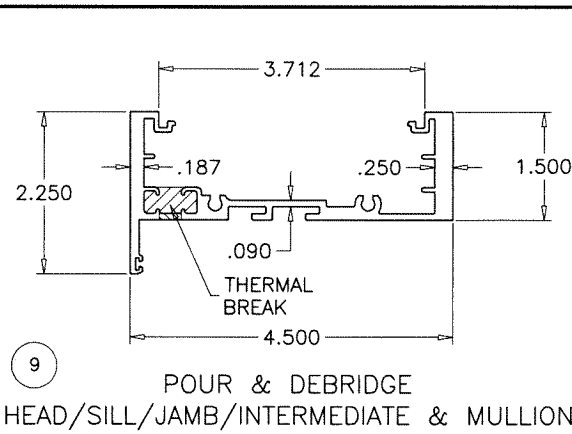

9 POUR & DEBRIDGE HEAD/SILL/JAMB/INTERMEDIATE & MULLION

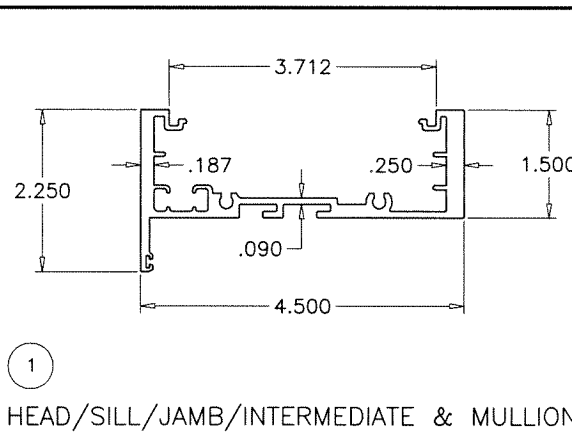

1 HEAD/SILL/JAMB/INTERMEDIATE & MULLION

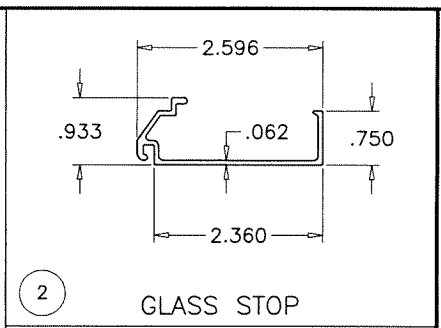

2 GLASS STOP

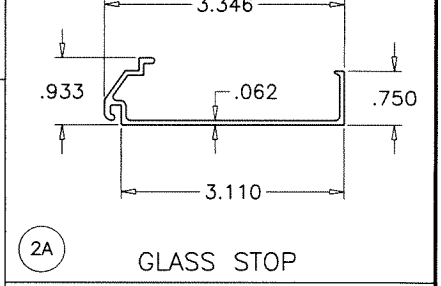

2A GLASS STOP

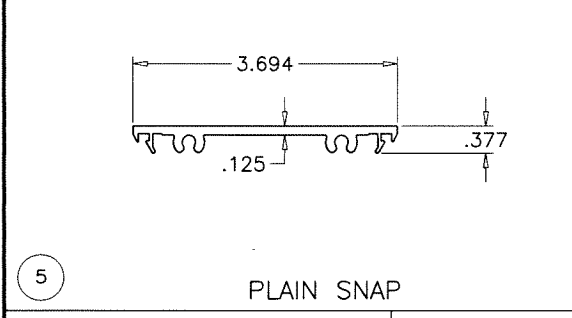

5 PLAIN SNAP

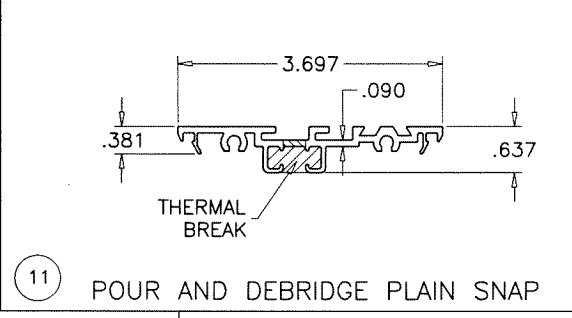

11 POUR AND DEBRIDGE PLAIN SNAP

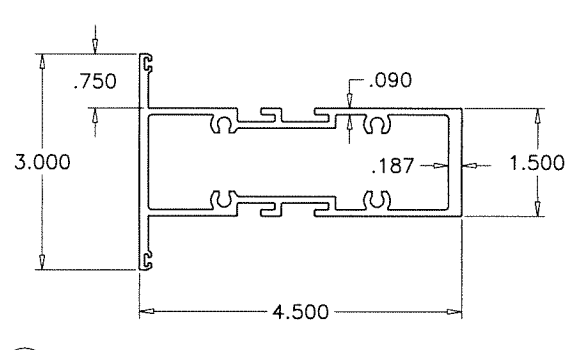

13 INTERMEDIATE HORIZONTAL

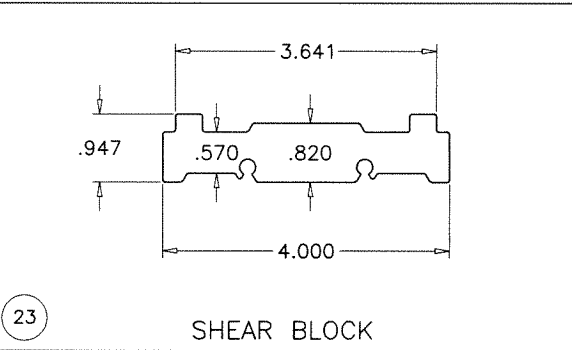

23 SHEAR BLOCK

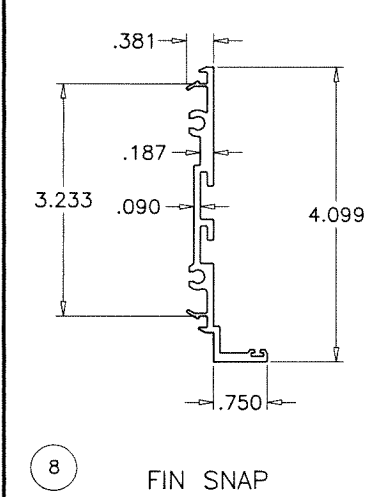

8 FIN SNAP

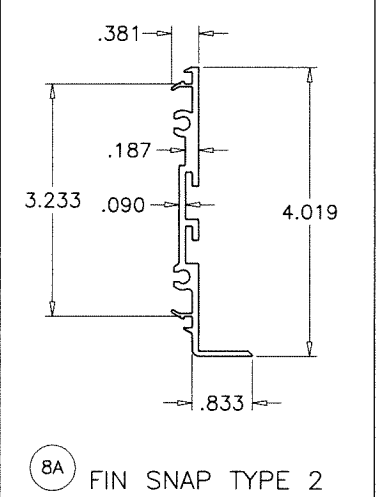

8A FIN SNAP TYPE 2

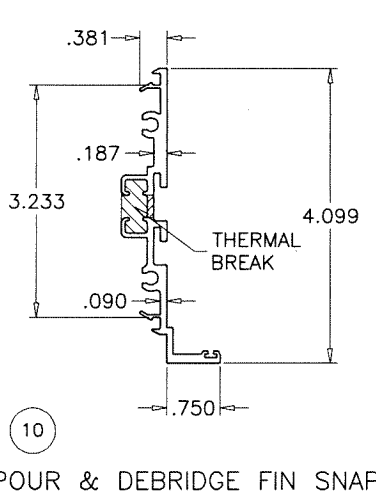

10 POUR & DEBRIDGE FIN SNAP

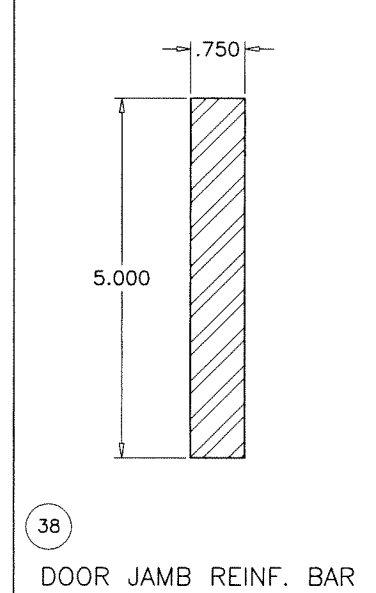

38 DOOR JAMB REINF. BAR

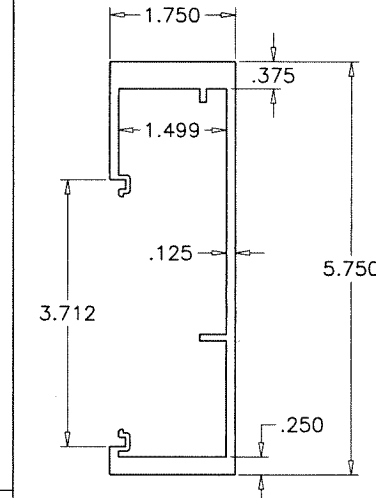

19 H.D. DOOR FRAME JAMB

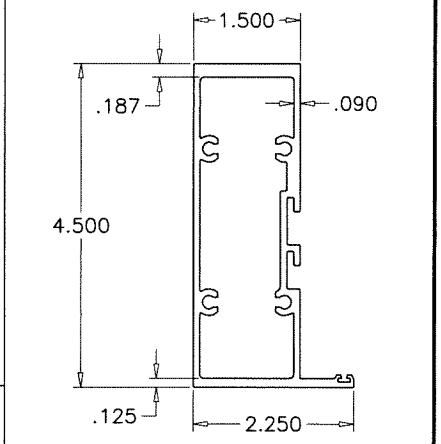

12 HEAD/JAMB/SILL

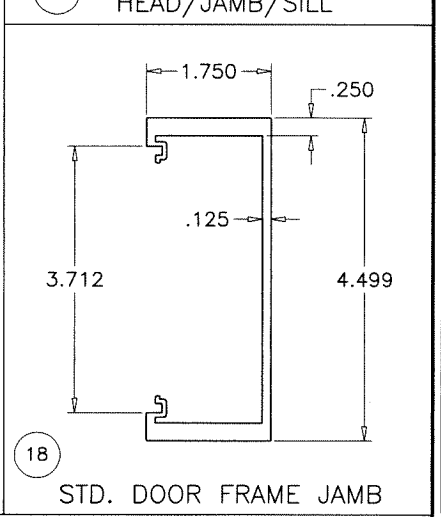

18 STD. DOOR FRAME JAMB

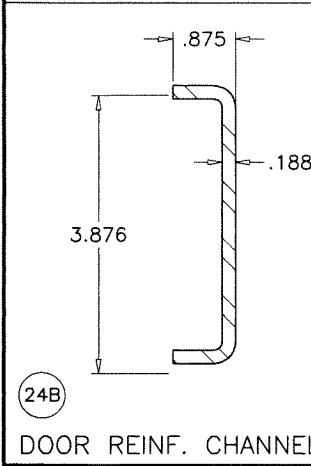

24B DOOR REINF. CHANNEL

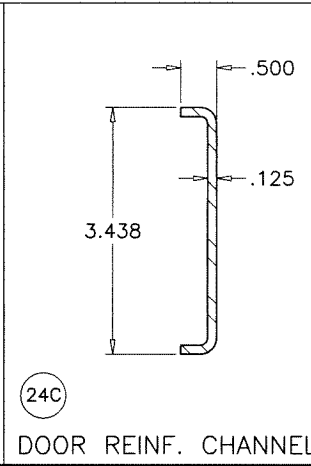

24C DOOR REINF. CHANNEL

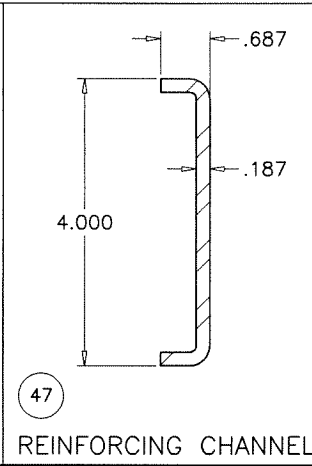

47 REINFORCING CHANNEL

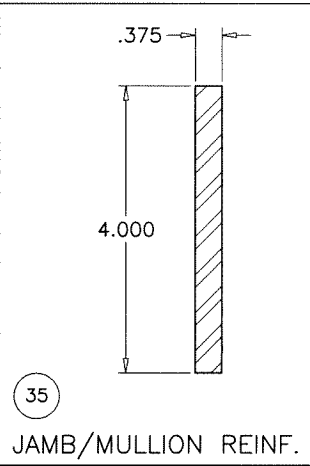

35 JAMB/MULLION REINF. BAR

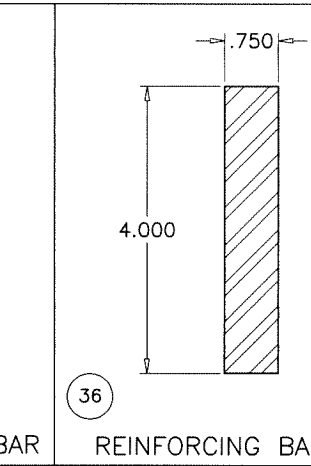

36 REINFORCING BAR

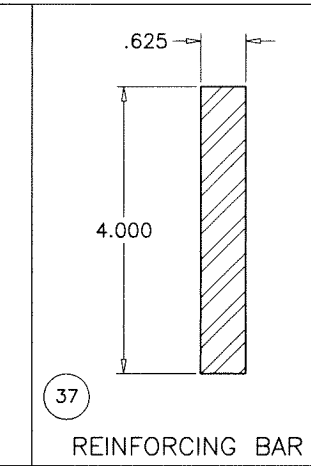

37 REINFORCING BAR

THERMAL BREAK:  
FRAME MEMBERS FILLED AND DEBRIDGED USING  
'AZON SU312-19T' STRUCTURAL THERMAL BARRIER POLYMER  
MANUFACTURED BY 'AZON USA INC.'

Sealed: 8/19/2025

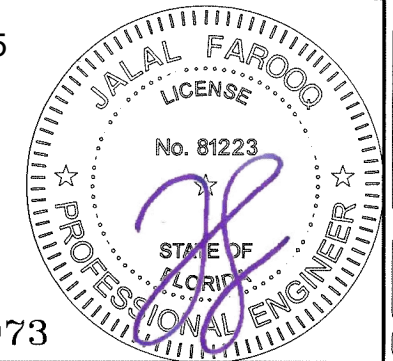

FL #19973

**af c**  
**AL-FAROOQ CORPORATION**  
ENGINEERS & PRODUCT DEVELOPMENT  
9360 SUNSET DRIVE, SUITE 220 (C.A.N. 3538)  
MIAMI, FLORIDA 33173  
TEL. (305) 264-8100 FAX. (305) 262-6978  
COMP-ANL\21-51FAGP

SERIES FRONT SET ALUM WINDOW WALL SYS. (L.M.I.)  
**Adora Aluminum & Glass Products Inc.**  
4250 Coral Ridge Drive, Suite 101  
Coral Springs, FL. 33065  
Tel. (954) 784-6900 Fax. (954) 784-6901

no	date	by	description

date: 06-10-21  
scale: 3/8" = 1"  
dr. by: TARIQ  
chk. by:  
drawing no.  
**21-51F**  
sheet 25 of 27

ITEM #	PART #	REQ'D	DESCRIPTION	MATERIAL	MANF. / SUPPLIER / REMARKS
1	SMI-311	AS REQ'D	HEAD, INTERM., SILL, JAMB AND MULLION- HEAVY.	6063-T6	-
2	SMI-312	AS REQ'D	GLASS STOP	6063-T6	-
2A	SMI-314	AS REQ'D	GLASS STOP (LARGER)	6063-T6	-
3	SMI-313	AS REQ'D	FIN SNAP	6063-T6	-
4	SMI-094	AS REQ'D	PLAIN SNAP	6063-T6	-
5	SMI-004	AS REQ'D	PLAIN SNAP	6063-T6	-
7	SMI-316	AS REQ'D	HEAD, INTERM., SILL, JAMB & MULLION- HEAVY	6063-T6	-
7A	SMI-321	AS REQ'D	INTERMEDIATE HORIZONTAL & MULLION- TYPE 2	6063-T6	-
8	SMI-317	AS REQ'D	FIN SNAP	6063-T6	-
8A	SMI-322	AS REQ'D	FIN SNAP TYPE 2	6063-T6	-
9	SMI-311T	AS REQ'D	POUR & DEBRIDGE HEAD, INTERM., SILL, JAMB & MULLION- HEAVY.	6063-T6	-
10	SMI-313T	AS REQ'D	POUR & DEBRIDGE FIN SNAP	6063-T6	-
11	SMI-094T	AS REQ'D	POUR & DEBRIDGE PLAIN SNAP	6063-T6	-
12	SMI-318	AS REQ'D	HEAD, JAMB & SILL.	6063-T6	-
13	SMI-319	AS REQ'D	INTERMEDIATE HORIZONTAL	6063-T6	-
18	SMI-005	AS REQ'D	STD. DOOR FRAME JAMB	6063-T6	-
19	SMI-076	AS REQ'D	H.D. DOOR FRAME JAMB	6005-T5	-
23	SMI-320	AS REQ'D	SHEAR BLOCK (1" LG.)	6063-T6	-
24B	7/8"x3 7/8"x7/8"	AS REQ'D	REINFORCING CHANNEL 3/16" THK.	STEEL	-
24C	1/2"x3 7/16"x1/2"	AS REQ'D	REINFORCING CHANNEL 1/8" THK.	STEEL	-
25	SMI-G01	AS REQ'D	GASKET (AT INTERIOR)	EPDM	TREMCO
26	SMI-G13	AS REQ'D	SPACER / RETAINER OUTER GASKET	SANTOPRENE	MELTPOINT PLASTICS INTERNATIONAL.
27	SMI-G02	AS REQ'D	SINGLE FACE FOAM TAPE (3/8" X 1/2")	VINYL FOAM	FRANK LOWE
31	SMI-SB04	2 PER GL.	SETTING BLOCKS (1/4" X 5/8" X 4" LG.)	EPDM	TREMCO, DUROMETER 80±5 SHORE A
34	SMI-SB07	2 PER GL.	SETTING BLOCKS (1/4" X 1 1/4" X 4" LG.)	EPDM	TREMCO, DUROMETER 80±5 SHORE A
35	3/8" X 4"	AS REQ'D	REINFORCING BAR	STEEL	A36, Fu MIN. = 58 KSI
36	3/4" X 4"	AS REQ'D	REINFORCING BAR	STEEL	A36, Fu MIN. = 58 KSI
37	5/8" X 4"	AS REQ'D	REINFORCING BAR	STEEL	A36, Fu MIN. = 58 KSI
38	3/4" X 5"	AS REQ'D	REINFORCING BAR	STEEL	A36, Fu MIN. = 58 KSI
46	#12 X 1 1/2"	4/CORNER	FRAME ASSEMBLY SCREWS	ST. STEEL	HEX. HEAD MACHINE SCREW
47	11/16"x 4" X 11/16"	AS REQ'D	JAMB/HORIZONTAL REINFORCING CHANNEL 3/16" THK.	STEEL	A36, Fu MIN. = 58 KSI

Sealed: 8/19/2025



FL #19973

**af c**  
**AL-FAROOQ CORPORATION**  
 ENGINEERS & PRODUCT DEVELOPMENT  
 9360 SUNSET DRIVE, SUITE 220 (C.A.N. 3538)  
 MIAMI, FLORIDA 33173  
 TEL. (305) 264-8100 FAX. (305) 262-6978  
 COMP-ANL\21-51FAGP

SERIES FRONT SET ALUM WINDOW WALL SYS. (L.M.I.)  
**Aldora Aluminum & Glass Products Inc.**  
 4250 Coral Ridge Drive, Suite 101  
 Coral Springs, FL. 33065  
 Tel. (954) 784-6900 Fax. (954) 784-6901

no	date	by	description

date: 06-10-21  
 scale: 3/8" = 1"  
 dr. by: TARIQ  
 chk. by:

drawing no.  
**21-51F**  
 sheet 26 of 27

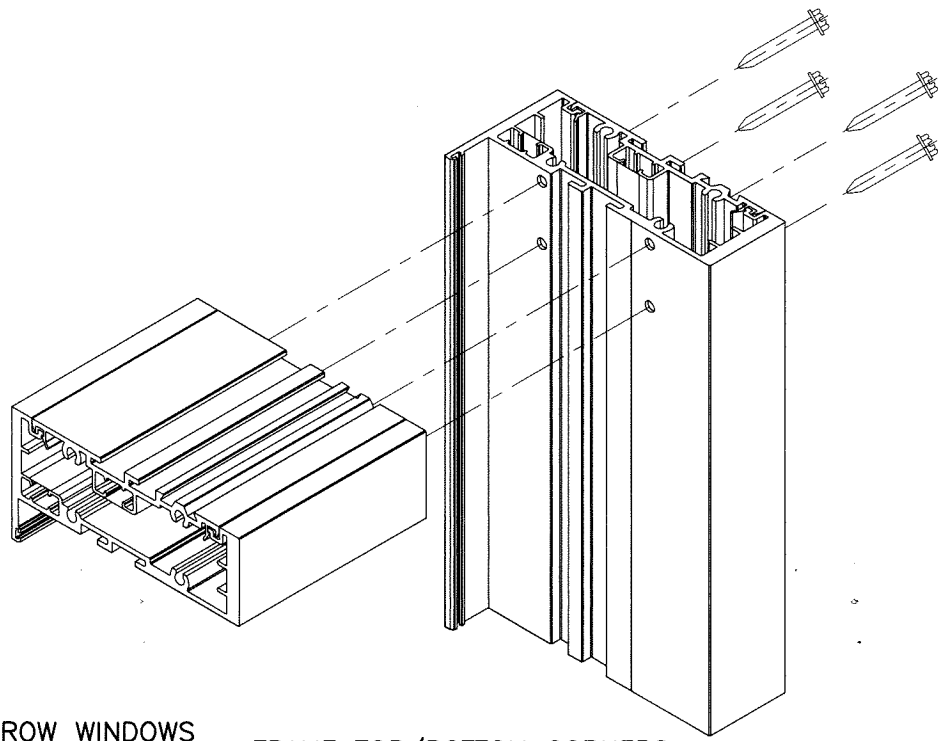

EYEBROW WINDOWS  
TOP CORNER

FRAME TOP/BOTTOM CORNERS

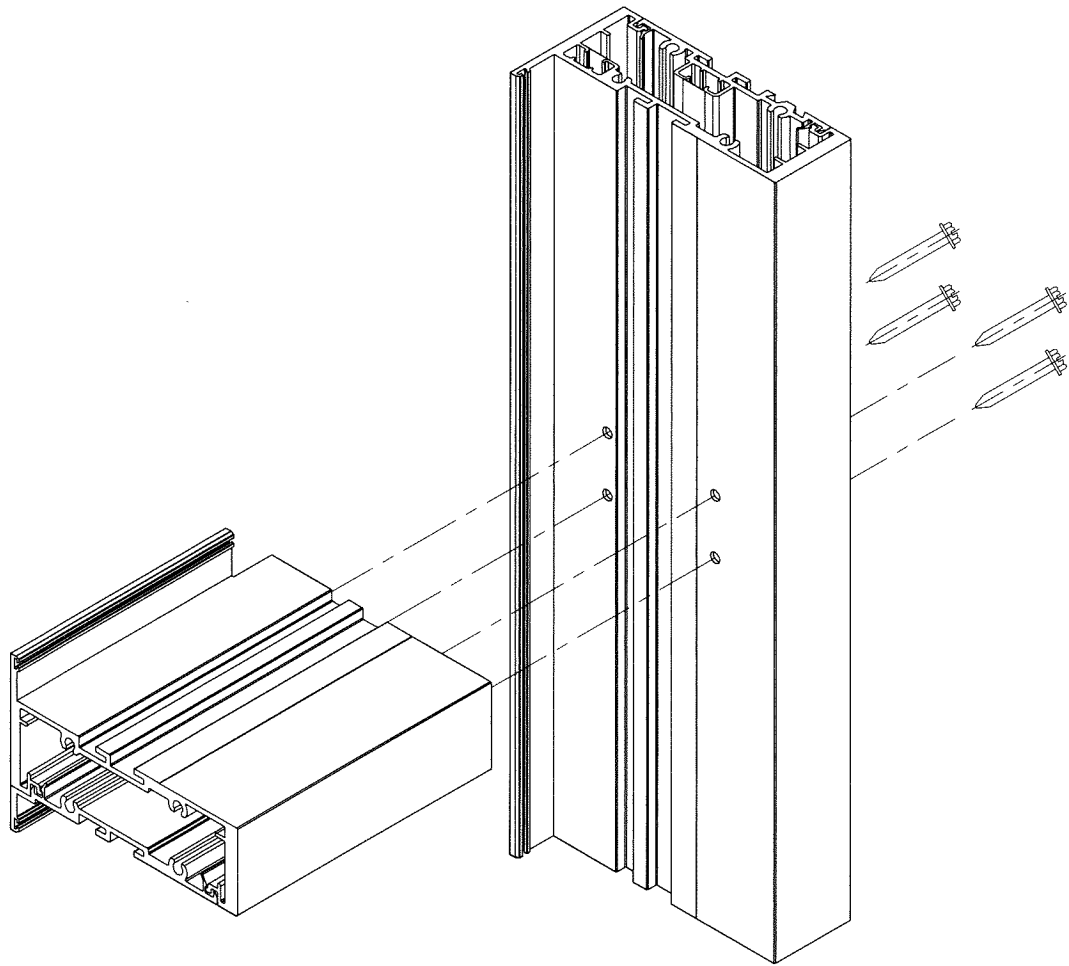

INTERMEDIATE HORIZONTAL CORNERS

1/4-20 X 1" LONG  
FT. HD. PH. MACHINE BOLT  
ST/ST WITH NUT  
(8) PER PLATE

1/8" X 4" ALUM PALTE  
10" LONG

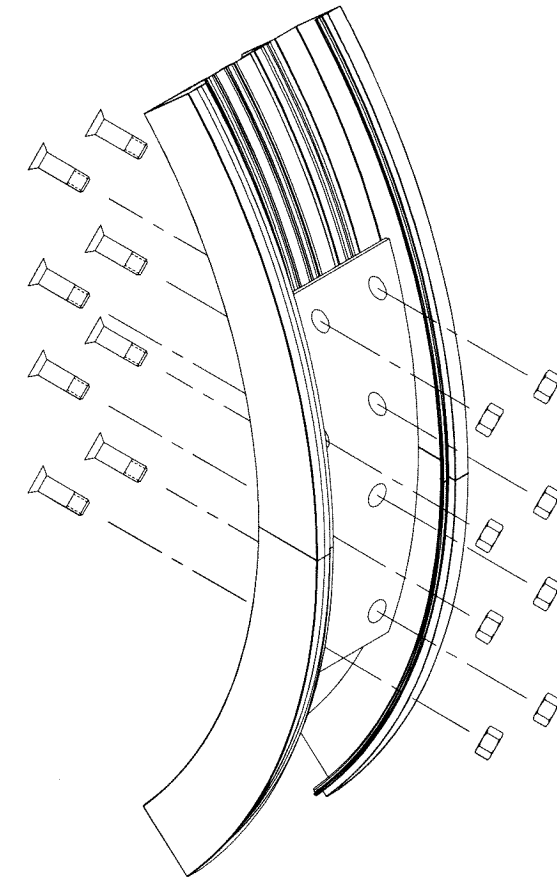
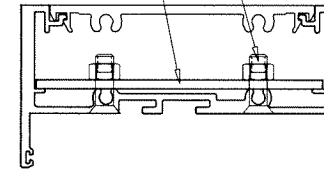

SPLICE JOINT AT  
HALF & FULL CIRCLE CORNERS

Sealed: 8/19/2025



FL #19973

**afc**  
**AL-FAROOQ CORPORATION**  
ENGINEERS & PRODUCT DEVELOPMENT  
9360 SUNSET DRIVE, SUITE 220 (C.A.N. 3588)  
MIAMI, FLORIDA 33173 TEL. (305) 264-8100 FAX. (305) 262-6978  
COMP-ANL\21-51FAGP

SERIES FRONT SET ALUM WINDOW WALL SYS. (L.M.I.)  
**Aldora Aluminum & Glass Products Inc.**  
4250 Coral Ridge Drive, Suite 101  
Coral Springs, FL. 33065  
Tel. (954) 784-6900 Fax. (954) 784-6901

revisions:	no	date	by	description

date: 06-10-21	scale: 3/8" = 1"	dr. by: TARIQ	chk. by:
drawing no. 21-51F			
sheet 27 of 27			